

# Intelligent Carrier Operating System (ICOS)

ICOS is a single-threaded OS kernel designed specifically for use on C&H's family of intelligent carriers for VXI. ICOS allows the user to fully operate the carrier and associated mezzanine modules as a standard VXI instrument. In addition, ICOS includes an Application Programming Interface (API) that allows the user to develop a user application to customize the functionality of the carrier. ICOS comes standard with all intelligent carriers and development tools are available from various 3<sup>rd</sup> party vendors.

## Overview:

### Intelligent Carriers

C&H Technologies' family of intelligent carriers provide an intelligent interface between various mezzanine modules and the VXI bus. Several variations exist, each providing a unique combination of mezzanine interfaces including M-modules, PMC modules, and PXI/cPCI modules.

Each carrier is powered by a highly integrated MPC8245 PowerPC<sup>®</sup> Microprocessor<sup>†</sup> with a PowerPC 603e core and a built-in peripheral component interconnect (PCI) interface. The processor along with SDRAM, flash and boot ROM memory create a standard embedded processing environment supported by many 3<sup>rd</sup> party, off-the-shelf development tools.

Each carrier also provides several utilities for communicating between the PowerPC application software

and the VXI bus. Utilities include a register-based interface, a VXI word serial command protocol interface and a block of shared memory accessible by both the PowerPC and VXI host applications.

### ICOS

C&H's Intelligent Carrier Operating System (ICOS) was designed to help the user operate any of the intelligent carriers in the C&H family. It provides routines to initialize the carrier, interact with the various hardware interfaces on the carrier, and communicate with the VXI bus via the word serial command protocol. It also contains a math library suitable for signal processing and analysis applications. Finally, it contains an Application Programming Interface (API) allowing the user to develop customized user applications to run on the embedded PowerPC.

ICOS is an interrupt-driven, single-threaded kernel that gives the user application complete control of the processor allowing it to act in a true real-time fashion. Once a user application is launched, ICOS does not actively perform any tasks. Instead, ICOS routines are called only when an interrupt occurs, signaling VXI communications or when the user application actively calls a system routine using the PowerPC's *system call* (sc) instruction.

The API provides an interface to an extensive set of utilities that assist the user in developing custom applications to run on the PowerPC. The application can customize the VXI interface by installing a word serial command interpreter and defining a set of VXI commands in addition to the system command already defined by ICOS. The application can also make use of 488.2 utilities, a system timer, the

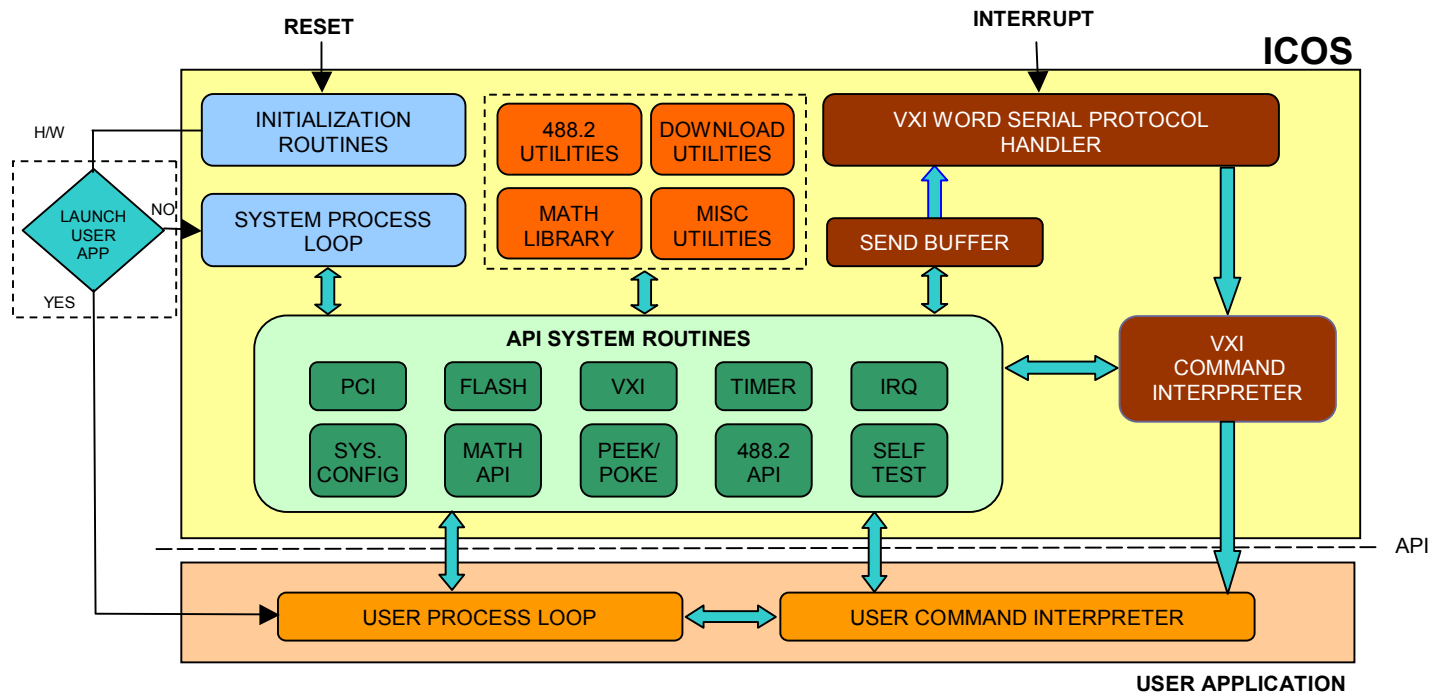

math library, and various hardware interface functions.

When no user application exists, a system process loop is launched allowing the carrier to function normally. In this mode, the VXI host has access to ICOS utilities and complete control of the carrier and associated mezzanine modules via the defined VXI system commands.

### Math Library

The embedded math library provides a list of functions suitable for processing and analyzing digitized signals. It is designed for applications using an intelligent carrier with on-board digitizing hardware, such as a Digital Storage Oscilloscope (DSO) or Analog to Digital Converter (ADC). The library allows the user to perform complex signal processing algorithms on-board the carrier, minimizing the amount of data that must be transferred over the VXI bus.

The math library is based upon the SigLib® DSP Library<sup>†</sup> from Numerix Ltd. Functionality includes spectrum analysis, digital filtering, statistical analysis, matrix algebra, and others.

A complete list of functions can be found in the ICOS User's Manual.

A user application has complete access to the math library functions via the API system calls. The VXI host can also access the math library through the defined VXI Commands.

### VXIpnp Driver & Soft Front Panel

A VXI Plug and Play (VXIpnp) driver and soft front panel is available for each intelligent carrier that allows the user to interact with the ICOS software and carrier hardware. The driver and soft front panel are valuable tools for developing and debugging user applications for the PowerPC and the VXI host.

The soft front panel application allows the user to interactively control the carrier and on-board software from the VXI host. The user can perform tasks such as: peek and poke any location in the PowerPC address space, program and erase flash memory, view the enumerated PCI bus, access registers, read and write to shared memory, and configure the ICOS software.

The function library provided with the VXIpnp driver can be used by an application, running on the VXI host, to access the carrier and on-board ICOS software. It provides high level functions for performing various tasks within the source code of the application. Many of the same tasks that can be interactively performed with the soft front panel are provided in the function library.

### Additional Information

ICOS comes automatically installed on all C&H intelligent carriers. The VXIpnp driver and soft front panel for each carrier can be downloaded from the support section of our website at [www.chtech.com](http://www.chtech.com).

User Manuals for ICOS and C&H's family of intelligent carriers can also be found on our website.

## Specifications:

### Kernel:

- Single-threaded
- Interrupt-driven
- System stack, data and text sections protected from user application
- Carrier initialization routine
- PCI Bus Enumeration
- Non-volatile configuration options
- System process loop allows normal operation when no user application exists
- Download utilities allow firmware updates via VXI bus

### User Application Support:

- Application is bootable from any PowerPC address
- Application can be downloaded via VXI at reset
- All 488.2 and VXI utilities are available
- Application can define VXI word serial commands in addition to those provided
- Application can override defined VXI commands and 488.2 *Star*(\*) commands
- System timer is available via the API system calls
- API system calls are linked at run-time allowing the user application to be compiled and linked independent of ICOS

### API System Calls: (Abbreviated List)

- **General:** Peek, Poke, Self Test, Timer, Shared Memory Base Address, ICOS Version Query
- **VXI Word Serial:** Send Message, Send Buffer Status, Enable/Disable, Install User Command Parser, Generate VXI Event Interrupt
- **PCI:** Configuration Read, Configuration Write
- **Flash:** Write, Read, Erase Sector, Block Write
- **Interrupts:** Configure, Enable/Disable, Acknowledge, Set Priority, Pending Query, Install Handler, Uninstall Handler
- **488.2:** Get/Set Status Register, Get/Set Status Enable Register, Set/Clear Status Bit, Set/Clear Status Enable Bit
- **Math:** Spectral Analysis (FFT, Power...), Statistics (Max, Min, Std. Deviation...), Waveform (RMS, Period, Pulse Width...), Digital Filters (FIR, IIR...), Windowing (Hanning, Blackman...), etc.
- For a complete list, refer to the ICOS User's Manual

### VXI Word Serial Protocol:

- Handles details of word serial communications
- Interrupt driven
- System command interpreter w/ defined commands
- User application can install a command interpreter

### VXI Commands: (Abbreviated List)

- **General:** Peek, Poke, ICOS Version Query, Error Query, Download
- **Flash:** Write, Read, Erase, Block Write
- **PCI:** Configuration Write, Configuration Read, Scan
- **ICOS Configuration:** Boot Address, VXI Manuf. ID, VXI Model Code, Return to Default
- **Math Library:** Process Data, Perform Math Function, Query Result
- For a complete list, refer to the ICOS User's Manual

### 488.2 Utilities and Commands:

- Status Byte and Status Byte Enable Registers
- Event Status and Event Status Enable Registers
- ***Star*(\*) commands:** \*IDN?, \*RST, \*TST?, \*OPC, \*OPC?, \*WAI, \*CLS, \*ESE, \*ESE?, \*ESR?, \*SRE, \*SRE?, \*STB?

### Math Library:

- Based on SigLib® DSP Library<sup>‡</sup>
- API System Call Interface
- VXI System Command Interface
- For a complete list of functions in the library, refer to the ICOS User's Manual

### ICOS Resource Usage:

- 1<sup>st</sup> four sectors of flash (256 kilobytes)
- 1 megabyte of RAM
- PowerPC's System Management Interrupt (SMI)

### VXIppn Driver & Soft Front Panel:

- Interactively control and configure ICOS
- Access carrier hardware and associated mezzanines
- Assists with debug and development of user applications for the PowerPC and VXI host.

### Development Options:

- Most 3<sup>rd</sup> party development tools for the MPC8245 PowerPC
- Development tool must be able to create and debug a standalone application
- Since the kernel is not active unless directly called or unless an interrupt occurs, most standard debug practices can be used (i.e. breakpoints, step, etc.)
- All intelligent carriers include a Common On-chip Processor (COP)/JTAG debug interface

<sup>†</sup> MPC8245 is a product of Motorola, Inc. PowerPC is a registered trademark of International Business Machines (IBM) Corporation used under license by Motorola.

<sup>‡</sup> Siglib is a product and trademark of Numerix Ltd.