

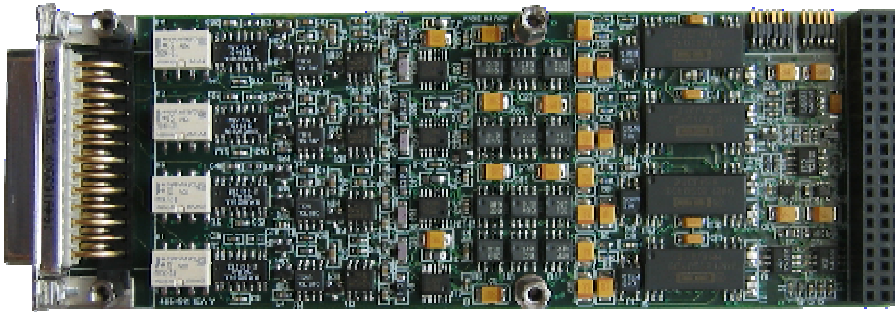

## M214 4-CHANNEL PRECISION DC REFERENCE M-MODULE

The M214 provides four precision four-wire voltage references in a single-wide M-module format. Each voltage reference is independent and individually optically isolated to allow independent thermocouple simulation. An on-board microcontroller provides precise control of the voltage references, including automatic temperature compensation.



### Overview:

The module has individual and individually optically isolated bipolar outputs with three voltage ranges to provide flexible output resolution options. Exceptional accuracy is ensured with on-board temperature measurement and automatic temperature compensation. All calibration constants are stored in on-board non-volatile memory.

An external analog input can be used for external temperature sensing. All outputs are short circuit protected.

Voltage control registers are double-buffered to allow fast continuous updates without waiting for internal operations.

### Front Panel I/O:

- 25-Pin female (socket) D-subminiature right angle connector (CONEC part number 164A10989X or equivalent).
- Any standard 25-pin male (plug) D-subminiature connector will mate with it.

### I/O Signals:

- HIx Source Output (High Side)
- LOx Source Output (Low Side)
- SENSEHIx Sense Input (High Side)
- SENSELOx Sense Input (Low Side)
- AIN External Analog Input (0 to 5V)
- +5VOUT Ext. Sensor Ref. Power
- GND External Ground Reference
- CHGND Chassis Ground\*

\* CHGND is capacitive coupled to GND

### M Module Compliance

Complies with ANSI/VITA Std. 12-1996 for single-wide M Modules, with the exception of +5V power consumption (see note 4)

Data Transfers: 16 bit

Compatible with VXI, LXI, PXI, VME, PCI, cPCI, Ethernet and other M Module carriers.

### Applications

- Thermocouple simulation
- Precision voltage source

### Ordering Information

**M214 M-Module** 11029260-0001

### Additional Information

User Manuals for C&H carriers and this module can be found on our website at [www.chtech.com](http://www.chtech.com).

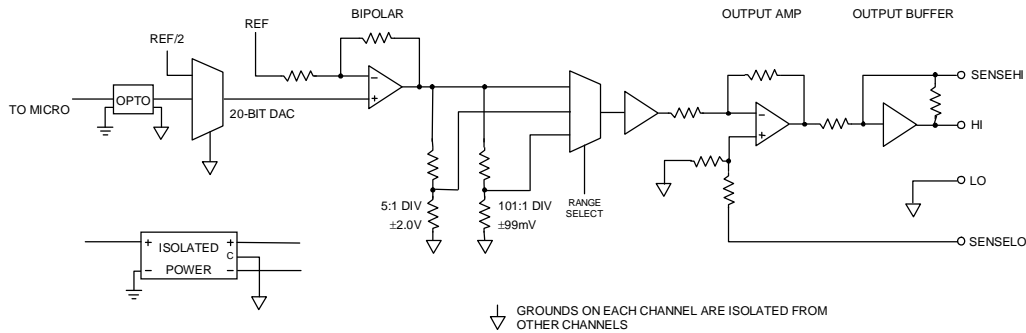
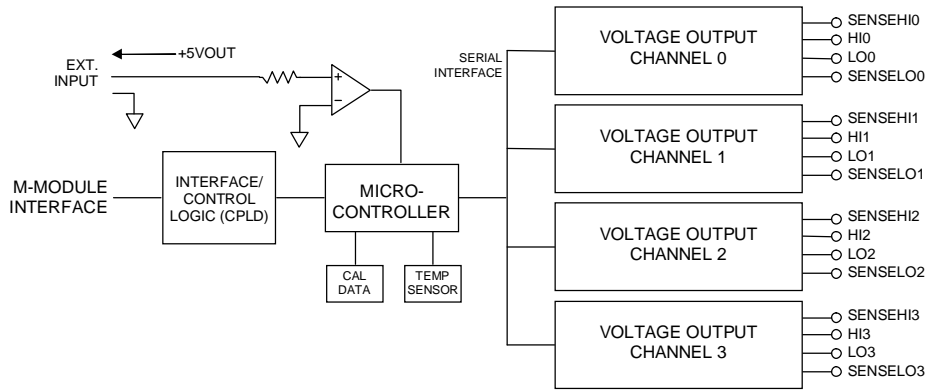

## Specifications:

### Voltage Source Outputs:

Output Voltage Ranges	$\pm 10.0\text{V}$ , $\pm 2.0\text{V}$ , & $\pm 99\text{mV}$
Voltage Resolution	
$\pm 10.0\text{V}$ range	19.1 $\mu\text{V}$
$\pm 2.0\text{V}$ range	3.81 $\mu\text{V}$
$\pm 99\text{mV}$ range	0.188 $\mu\text{V}$
Voltage Accuracy <sup>1,2</sup>	$\pm(0.01\%$ of setting + 0.005% of range + 15 $\mu\text{V}$ )
Linearity Error	$\pm 0.0015\%$
Output Current	$\pm 10\text{ma}$ min
Programming Time <sup>3</sup>	6.5ms max
Slew Rate	100V/s

### +5VOUT

Voltage Accuracy	$\pm 1.0\%$
Thermal Coefficient	20ppm/ $^{\circ}\text{C}$
Output Current	30ma min

### AIN (Analog Input)

Data Resolution	10bits
A/D Conversion Error	0.5 LSB
Input Range (operational)	$\pm 5\text{V}$
Input Voltage (no damage)	$\pm 20\text{V}$
Accuracy	$\pm(1.5\% + 10\text{mV})$
Input Current	800nA max

### On-board Temperature

Data Resolution	10bits
Accuracy	$\pm 3^{\circ}\text{C}$

### Power:

+5V	1200 ma <sup>4</sup>
+12V	20 ma
-12V	15 ma

### Temperature:

Operating	$0^{\circ}\text{C}$ to $50^{\circ}\text{C}$
Storage	$-40^{\circ}\text{C}$ to $70^{\circ}\text{C}$

### Notes:

1. The output level is automatically temperature compensated by the on-board processor. The specified accuracy is typically maintained for a wider temperature difference; however, it is not guaranteed. Unit should be allowed to stabilize for a minimum of 5 minutes after power-up.
2. Accuracy may be somewhat degraded at the limits of each range. Stay within 98% of full scale for specified accuracy.
3. Register write to start of output change.
4. The +5V power consumption exceeds the ANSI/VITA 12-1996 Specification for M-modules. Be sure check the specifications of the M-module carrier and system environment to ensure that it can handle the rated current load and heat dissipation.