

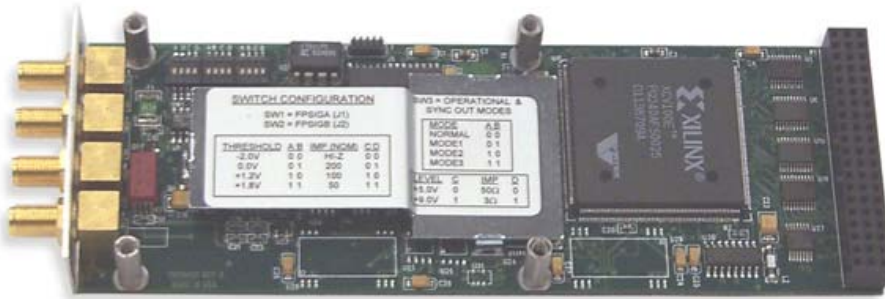

# MA204 50MHz Pulse Generator

The MA204 is a fully programmable pulse generator that allows the generation of precisely timed pulses of programmable frequency, pulse width, delay, and amplitude. Operational modes include single, continuous, and burst functions along with double pulse capability. Extensive trigger and gating logic provides comprehensive control of pulse timing. The internal base clock can be disciplined to an external reference clock.



## Overview:

**Number of Channels:** 1  
**Frequency:** 0.2Hz - 50MHz  
**Pulse Output:** -2V to +7V

### Operational Modes:

- Single or continuous pulsing
- Single pulse or pulse pair
- Programmable rise/fall time
- External triggering
- Async. or sync. gating
- Burst from 2 to >4B pulses

### Clock Disciplining:

Internal clock can be disciplined to a 10MHz external reference for increased accuracy and stability

### Calibration:

Calibration is normally not required, however, registers are provided that allow fine adjustment of the delay times.

### Inputs/Outputs:

- Front Panel Pulse Output
- Front Panel Sync Output
- Front Panel Input A
- Front Panel Input B
- M-Module Trig A
- M-Module Trig B

### Gate, Trigger, Ref. Clock inputs:

Source can be the front panel A or B connectors or the MA-Module Trig A or Trig B signals

### Pulse and Sync outputs:

Can be directed to the front panel connectors and to the MA-Module backplane Trig A or B signals

**Front Panel Connectors:** SMA

## Ordering Information

### Part Number

100ps timing	11028450-0001
5ns timing	11028450-0002

## M Module Compliance

Complies with ANSI/VITA Std. 12-1996 for single-wide MA Modules

Data Transfers: 16 bit

Interrupts: INTA & INTC

Triggers: TRIGA & TRIGB

Compatible with VXI, VME, PCI, cPCI and other M Module carriers.

## Applications

- Functional testing
- Design verification
- Signal simulation
- Timing control

## Additional Information

User Manuals for C&H carriers and this module can be found on our website at [www.chtech.com](http://www.chtech.com).

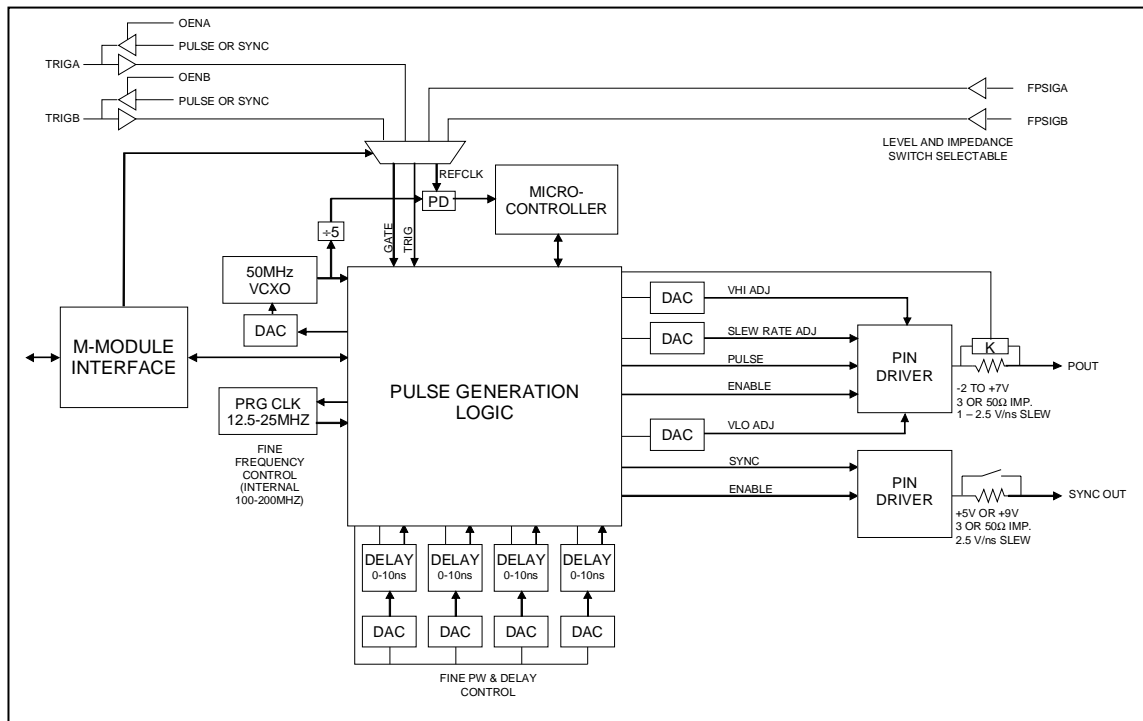

## Specifications:

### Pulse Period:

Range (internal triggering)	20ns to 5.2s
Programming Step Size	100ps
Resolution <sup>1</sup>	20 to 79.9ns
	80 to 159.9ns
	160 to 319.9ns
	320 to 639.9ns
	640 to 1279.9ns
	1280 to 4999.9ns
≥ 5μs period	5ns
Accuracy (internal clock)	±(0.01% + 100ps) <sup>2</sup>

### Pulse Width:

Range	10ns <sup>3</sup> to 5.2s
Prog. Resolution	-0001 version
	-0002 version
Accuracy (internal clock)	±(0.01% + 2ns) <sup>2,4</sup>

### Pulse Delay (from Sync Out):

Range	20ns to 5.2s
Prog. Resolution	-0001 version
	-0002 version
Accuracy (internal clock)	±(0.01% + 2ns) <sup>2,4</sup>

### Pulse Out Characteristics:

Range	-2.0V to +7.0V
Impedance (programmable)	3Ω or 50Ω
Prog. Resolution	25mV
Accuracy	±(2.0% + 100mV)
Output Current (source or sink)	50mA
Short Circuit Current (static)	±35mA max
Short Circuit Current (dynamic)	±100mA max
Rise/Fall Time (prog, R <sub>L</sub> = ∞)	1.0 to 2.5V/ns

### Input Characteristics (FPSIGA & FPSIGB):

Impedance (selectable)	56, 82, 180, or >100KΩ
Threshold (selectable)	-2.0, 0, +1.2, or +1.8V
Frequency	50MHz max
Pulse Width	10ns min

### Sync Out Characteristics:

Time to un-delayed output pulse	
	-0001 version
	-0002 version
Time from external trigger	80ns max
Output Impedance (selectable)	3Ω or 50Ω
Amplitude (selectable, R <sub>L</sub> = ∞)	5.0V or 9.0V
Output Current (source or sink)	50mA
Rise/Fall Time (R <sub>L</sub> = ∞)	2.5V/ns typ
Pulse Width	period < 80ns
	period ≥ 80ns

### Power: (-0001/-0002)

+5V	1.3A / 200ma
+12V	200ma / 170ma
-12V	200ma / 180ma

### Temperature:

Operating	0°C to 50°C
Storage	-40°C to 70°C

### Notes:

- In general, the resolution is 100ps when programming a period less than 5μs; however, there are some areas that have less resolution as specified for the various ranges. See the User Manual for further details.
- The percent accuracy can be improved by disciplining the internal clock to an external precision 10MHz reference clock. The internal clock accuracy will discipline in about 10 minutes to within one decade of the external reference, up to 10<sup>-8</sup> accuracy.
- For pulse periods < 40ns, pulse width = ½ period. For periods ≥ 40ns the minimum pulse width = 15-30ns. See User Manual for further details.
- Use of the calibration register can improve this accuracy.