



# MA209 100MHz Pulse Generator

The MA209 is a fully programmable pulse generator that allows the generation of precisely timed pulses of programmable frequency, pulse width, delay, and amplitude. Operational modes include single, continuous, burst, and follow trigger modes. Extensive trigger and gating logic provides comprehensive control of pulse timing and the internal base clock can be disciplined to an external reference clock.

## Overview:

**Number of Channels:** 1  
**Frequency:** 0.1Hz - 100MHz  
**Pulse Output:** -1.5V to +6.5V

### Operational Modes:

- Single or continuous pulsing
- Single pulse or double pulse
- Burst from 2 to >1B pulses
- Follow trigger
- Inverted Pulse/Sync
- Programmable rise/fall time
- External triggering
- Asynchronous or synchronous gating

### Clock Disciplining:

Internal clock can be disciplined to a 10MHz external reference for increased accuracy and stability

### Inputs/Outputs:

- Front Panel Pulse & Sync Out
- Front Panel Input A & B
- M-Module Trig A & B

### Gate, Trigger, Ref. Clock Inputs:

Source can be the front panel A or B connectors or the M-Module Trig A or Trig B signals

### Pulse and Sync Outputs:

Can be directed to the front panel connectors and to the M-Module backplane Trig A or B signals

**Front Panel Connectors:** SMA

## Ordering Information

**Part Number** 11028790-0001

## M Module Compliance

Complies with ANSI/VITA Std. 12-1996 for single-wide M-Modules

Data Transfers: 16 bit  
Interrupts: INTA & INTC  
Triggers: TRIGA & TRIGB  
Compatible with VXI, VME, PCI, cPCI and other M Module carriers.

## Applications

- Functional testing
- Design verification
- Signal simulation
- Timing control

## Additional Information

User Manuals for C&H carriers and this module can be found on our website at [www.chtech.com](http://www.chtech.com).

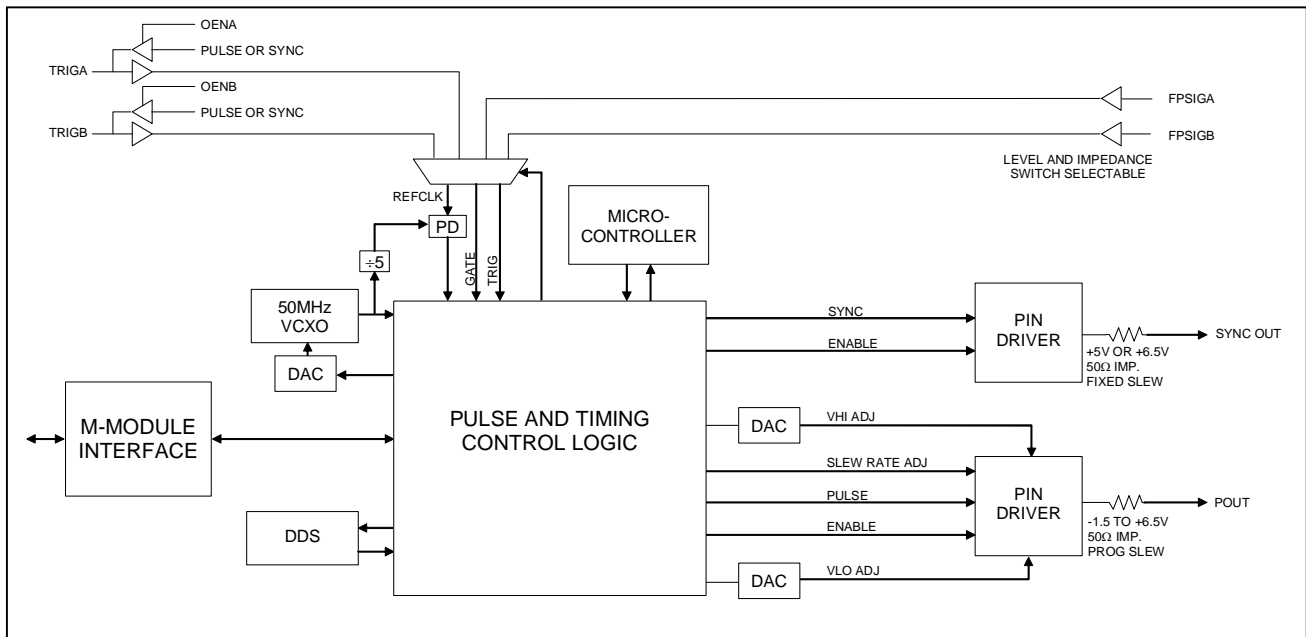

## Specifications:

### Pulse Frequency (internal clock):

Range	0.093Hz to 100MHz
Resolution	0.093Hz
Accuracy	$\pm 0.01\%$ <sup>1</sup>

### Pulse Width:

Range	5ns to (period – 3ns)
Accuracy	$\pm(3\% + 250ps)$ <sup>2</sup>

### Pulse Delay (from Sync Out):

Range	5ns <sup>3</sup> to 5s
Accuracy	$\pm(3\% + 250ps)$ <sup>2</sup>

### Double Pulse Spacing:

Range	(width + 3ns) to (period – width – 3ns)
Accuracy	$\pm(3\% + 250ps)$ <sup>2</sup>

### Timing (Width, Delay, Double Spacing):

Resolution	4 to 13ns	10ps
	13 to 24ns	20ps
	$\geq 24ns$	see note 4
Temperature Coefficient	$+17ppm/^{\circ}C$ typ	

### Pulse Out Characteristics:

Range ( $R_L = \infty$ )	-1.5V to +6.5V
Output Impedance	50 $\Omega$
Resolution (12 bit)	2mV
Accuracy	$\pm(2.0\% + 100mV)$
Output Current (source or sink)	60mA
Short Circuit Current (dynamic)	$\pm 120mA$ max
Rise/Fall Time (prog, $R_L = \infty$ )	0.625 to 2.5V/ns

### Temperature:

Operating	0 $^{\circ}C$ to 50 $^{\circ}C$
Storage	-40 $^{\circ}C$ to 70 $^{\circ}C$

### Input Characteristics (FPSIGA & FPSIGB):

Threshold (programmable)	-5.0V to +5.0V
Resolution (8 bit)	39mV
Impedance (selectable)	50 or $>10K\Omega$
Accuracy (mid-point falling/rising)	$\pm(5\% + 150mV)$
Hysteresis	50-350mVpp
Frequency	100MHz max
Pulse Width	3ns min
Maximum Input Voltage (no damage)	$\pm 12V_{rms}$

### Sync Out Characteristics:

Time from external trigger	$<35ns$ <sup>5</sup>
Output Impedance	50 $\Omega$
Amplitude (selectable, $R_L = \infty$ )	5.0V or 6.5V
Output Current (source or sink)	60mA
Rise/Fall Time ( $R_L = \infty$ )	2.5V/ns typ
Width (software selectable)	5ns or 55ns

### Power:

+5V	1500ma max
+12V	400ma max
-12V	330ma max

### Notes:

- The percent accuracy can be improved by disciplining the internal clock to an external precision 10MHz reference clock. The internal clock accuracy will discipline in about 10 minutes to within one decade of the external reference, up to  $10^{-8}$  accuracy.
- Accuracy is within the tolerance specified at the calibration temperature. Temperature coefficient can be used to correct for temperature variation.
- The pulse delay can be programmed to zero; however, the minimum Sync Out time to output pulse specification applies.
- For times  $\geq 24ns$ , the timing resolution increases approx. 10ps for every 12ns increase in time.
- The Sync Out time specified is from the external front panel trigger to the external front panel Sync Out. Backplane trigger timing will vary depending on the carrier used.