



**CAUTION**  
This product requires a PXI/cPCI Chassis with replaceable card guides per the Eurocard mechanical specification



## PX464S 50MHz Pulse Generator

The PX464S is a one or two channel fully programmable pulse generator that allows the generation of precisely timed pulses of programmable frequency, pulse width, delay, and amplitude. Operational modes include single, continuous, and burst functions along with double pulse capability. Extensive trigger and gating logic provides comprehensive control of pulse timing. The internal base clock can be disciplined to an external reference clock.

### Overview:

**Number of Channels:** 1 or 2  
**Frequency:** 0.2Hz - 50MHz  
**Pulse Output:** -2V to +7V

#### Operational Modes:

- Single or continuous pulsing
- Single pulse or pulse pair
- Programmable rise/fall time
- External triggering
- Async. or sync. gating
- Burst from 2 to >4B pulses

#### Clock Disciplining:

Internal clock can be disciplined to a 10MHz external reference for increased accuracy and stability

#### Calibration:

Calibration is normally not required, however, registers are provided that allow fine adjustment of the delay times.

#### Inputs/Outputs (each channel):

- Front Panel Pulse Output
- Front Panel Sync Output
- Front Panel Input A
- Front Panel Input B
- PXI Trigger (5)

#### Gate, Trigger, Ref. Clock inputs:

Source can be the front panel A or B connectors or a PXI trigger

#### Pulse and Sync outputs:

Can be directed to the front panel connectors and to a PXI trigger

**Front Panel Connectors:** SMA

### Ordering Information

**Part Number**  
Single Channel 11029170-0001  
Dual Channel 11029170-0002

### CPCI/PXI Compliance

Complies with PCI spec. 2.0 R3.0 and PCI spec 2.2

5V and 3.3V signaling voltage (VIO) supported

5V only power supply

33MHz PCI data bus

Five trigger lines compliant with PXI Specification 2.1

Form Factor: Size 3U

### Applications

- Functional testing
- Design verification
- Signal simulation
- Timing control

### Additional Information

User Manuals and drivers for C&H modules can be found on our website at [www.chtech.com](http://www.chtech.com).

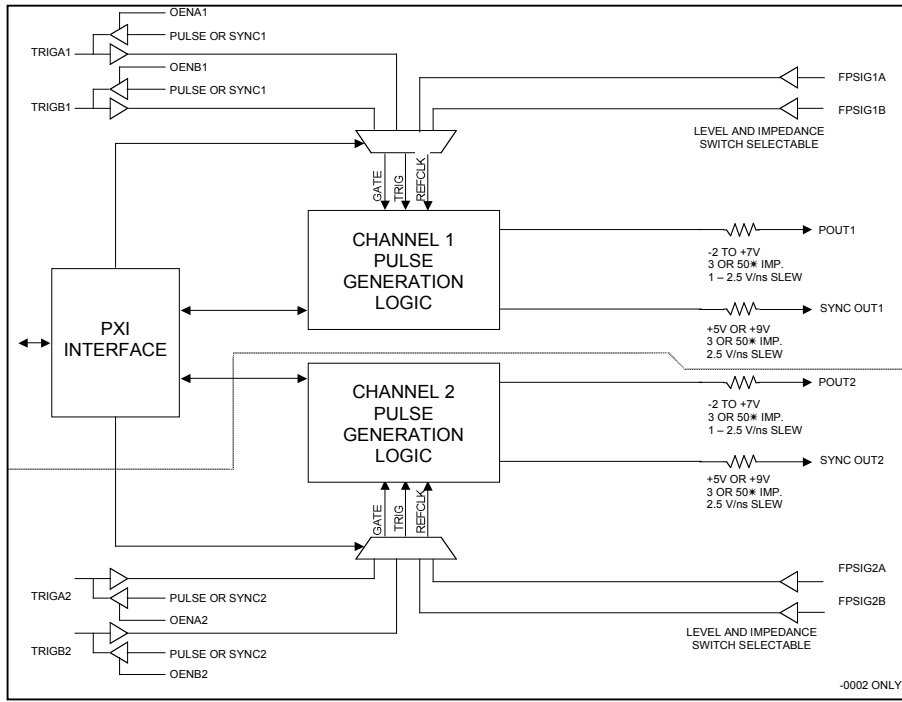

## Specifications:

### Pulse Period:

Range (internal triggering)	20ns to 5.2s
Programming Step Size	100ps
Resolution <sup>1</sup>	20 to 79.9ns
	80 to 159.9ns
	160 to 319.9ns
	320 to 639.9ns
	640 to 1279.9ns
	1280 to 4999.9ns
	5µs period
Accuracy (internal clock)	±(0.01% + 100ps) <sup>2</sup>

### Pulse Width:

Range	10ns <sup>3</sup> to 5.2s
Prog. Resolution	5ns
Accuracy (internal clock)	±(0.01% + 2ns) <sup>2,4</sup>

### Pulse Delay (from Sync Out):

Range	20ns to 5.2s
Prog. Resolution	5ns
Accuracy (internal clock)	±(0.01% + 2ns) <sup>2,4</sup>

### Pulse Out Characteristics:

Range	-2.0V to +7.0V
Impedance (programmable)	3 or 50
Prog. Resolution	25mV
Accuracy	±(2.0% + 100mV)
Output Current (source or sink)	50mA
Short Circuit Current (static)	±35mA max
Short Circuit Current (dynamic)	±100mA max
Rise/Fall Time (prog, R <sub>L</sub> = )	1.0 to 2.5V/ns

### Input Characteristics (FPSIGAx & FPSIGBx):

Impedance (selectable)	56, 82, 180, or >100K
Threshold (selectable)	-2.0, 0, +1.2, or +1.8V
Frequency	50MHz max
Pulse Width	10ns min

### Sync Out Characteristics:

Time to un-delayed output pulse	4ns typ
Time from external trigger	80ns max
Output Impedance (selectable)	3 or 50
Amplitude (selectable, R <sub>L</sub> = )	5.0V or 9.0V
Output Current (source or sink)	50mA
Rise/Fall Time (R <sub>L</sub> = )	2.5V/ns typ
Pulse Width	period < 80ns
	period 80ns

### Power: (-0001/-0002)

+5V	800mA / 600mA
+12V	340mA / 170mA
-12V	360mA / 180mA

### Temperature:

Operating	0°C to 50°C
Storage	-40°C to 70°C

### Notes:

- In general, the resolution is 100ps when programming a period less than 5µs; however, there are some areas that have less resolution as specified for the various ranges. See the User Manual for further details.
- The percent accuracy can be improved by disciplining the internal clock to an external precision 10MHz reference clock. The internal clock accuracy will discipline in about 10 minutes to within one decade of the external reference, up to 10<sup>-8</sup> accuracy.
- For pulse periods < 40ns, pulse width = 1/2 period. For periods 40ns the minimum pulse width = 15-30ns. See User Manual for further details.
- Use of the calibration register can improve this accuracy.