



CAUTION
This product requires a PXI/cPCI Chassis with replaceable card guides per the Eurocard mechanical specification

PX468S 4-Channel Precision DC Reference Module

The PX468S provides four precision four-wire voltage references in a single-wide M-module format. Each voltage reference is independent and individually optically isolated to allow independent thermocouple simulation. An on-board microcontroller provides precise control of the voltage references, including automatic temperature compensation.

This unit also features a position for adding one single-wide M-Module.

Overview:

The module has individual and individually optically isolated bipolar outputs with three voltage ranges to provide flexible output resolution options. Exceptional accuracy is ensured with on-board temperature measurement and automatic temperature compensation. All calibration constants are stored in on-board non-volatile memory.

An external analog input can be used for external temperature sensing. All outputs are short circuit protected.

Voltage control registers are double-buffered to allow fast continuous updates without waiting for internal operations.

Front Panel I/O:

- 25-Pin female (socket) D-subminiature right angle connector (CONEC part number 164A10989X or equivalent).
- Any standard 25-pin male (plug) D-subminiature connector will mate with it.

I/O Signals:

- Hlx Source Output (High Side)
- LOx Source Output (Low Side)
- SENSEHlx Sense Input (High Side)
- SENSELOx Sense Input (Low Side)
- AIN External Analog Input (0 to 5V)
- +5VOUT Ext. Sensor Ref. Power
- GND External Ground Reference
- CHGND Chassis Ground*

* CHGND is capacitive coupled to GND

CPCI/PXI Compliance

Complies with PCI spec. 2.0 R3.0 and PCI spec 2.2

5V and 3.3V signaling voltage (VIO) supported

5V only power supply

33MHz PCI data bus

Five trigger lines compliant with PXI Specification 2.1

Form Factor: Size 3U

Applications

- Thermocouple simulation
- Precision voltage source

Ordering Information

Part Number 11029260-0001

Additional Information

User Manuals for C&H carriers and this module can be found on our website at www.chtech.com.

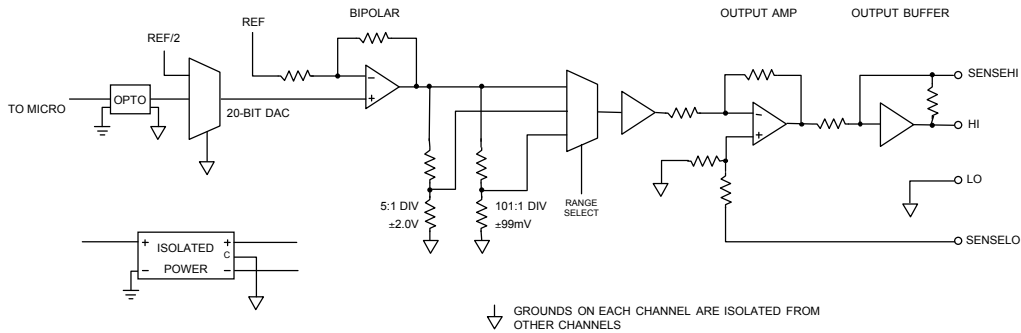
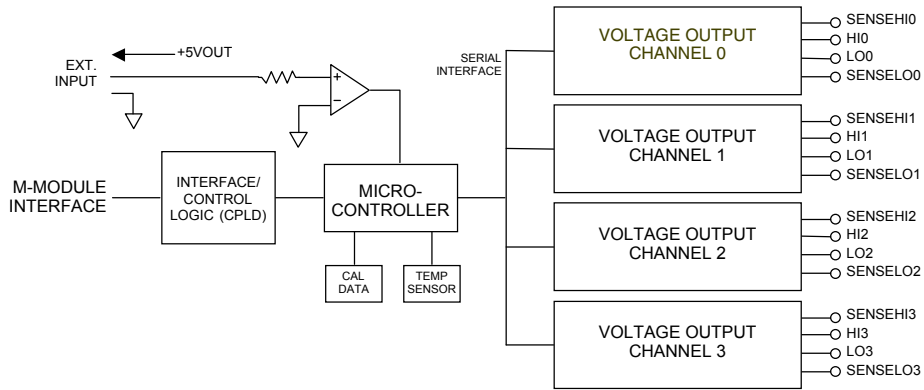

Specifications:

Voltage Source Outputs:

Output Voltage Ranges	±10.0V, ±2.0V, & ±99mV
Voltage Resolution	
±10.0V range	19.1μV
±2.0V range	3.81μV
±99mV range	0.188μV
Voltage Accuracy ^{1,2}	±(0.01% of setting + 0.005% of range + 15μV)
Linearity Error	±0.0015%
Output Current	±10ma min
Programming Time ³	6.5ms max
Slew Rate	100V/s

+5VOUT

Voltage Accuracy	±1.0%
Thermal Coefficient	20ppm/°C
Output Current	30ma min

AIN (Analog Input)

Data Resolution	10bits
A/D Conversion Error	0.5 LSB
Input Range (operational)	±5V
Input Voltage (no damage)	±20V
Accuracy	±(1.5% + 10mV)
Input Current	800nA max

On-board Temperature

Data Resolution	10bits
Accuracy	±3°C

Power:

+5V	1.6 A
+12V	0.02 A
-12V	0.015 A

Temperature:

Operating	0°C to 50°C
Storage	-40°C to 70°C

Notes:

1. The output level is automatically temperature compensated by the on-board processor. The specified accuracy is typically maintained for a wider temperature difference; however, it is not guaranteed. Unit should be allowed to stabilize for a minimum of 5 minutes after power-up.
2. Accuracy may be somewhat degraded at the limits of each range. Stay within 98% of full scale for specified accuracy.
3. Register write to start of output change.