

U S E R ' S M A N U A L

VXI 16-CHANNEL
FREQUENCY
SOURCE

MODEL
VX461C

COPYRIGHT

C&H Engineering, Inc. (C&H) provides this manual "as is" without warranty of any kind, either expressed or implied, including but not limited to the implied warranties of merchant ability and fitness for a particular purpose. C&H may make improvements and/or changes in the product(s) and/or program(s) described in this manual at any time and without notice.

This publication could contain technical inaccuracies or typographical errors. Changes are periodically made to the information herein; these changes will be incorporated in new editions of this publication.

Copyright © 1993, 1997 by C&H Engineering, Inc.

The information and/or drawings set forth in this document and all rights in and to inventions disclosed herein which might be granted thereon disclosing or employing the materials, methods, techniques or apparatus described herein, are the exclusive property of C&H Engineering, Inc.

A Reader's Comment Form is provided at the back of this publication. If this form has been removed address comments to:

C&H Engineering, Inc.
Technical Publications
P. O. Box 14765
Austin, Texas 78761-4765

C&H may use or distribute any of the information you supply in any way that it believes appropriate without incurring any obligations whatever.

VME/VXI MODULE WARRANTY

C&H Engineering, Inc. warrants its VME/VXI products to be free from defects in material and workmanship for three years from date of shipment. C&H will repair or replace the defective product without charge within the warranty period, provided the defective item is shipped, freight prepaid, to C&H Engineering, at 15809 Vision Drive, Pflugerville, TX 78660. C&H will pay return freight charges to any point in the continental United States or Canada.

Obligations under this warranty shall be limited to repair or replacement, at C&H's discretion, of any product or part thereof which has been returned by the original purchaser with transportation prepaid and, upon examination by C&H, found to be defective. C&H assumes no responsibility for loss or damage to equipment being returned for repair or replacement under the terms of this warranty. Equipment which, upon examination by C&H, requires repair or replacement of parts thereof as a result of improper installation, misuse, unauthorized alterations or repairs, or user negligence, will have such repairs or replacement of parts made at then current rates.

This warranty does not cover damage caused by misuse, neglect, accident, or improper application or installation. C&H shall not be liable for consequential damages of any kind arising out of the purchase, installation, use or misuse of the product. C&H makes no representation or warranty of any kind, either expressed or implied, with respect to equipment operation or procedures. Any action that the user may take in reliance upon the operation or accuracy of this equipment shall be taken solely at the user's own responsibility and risk.

Please notify the C&H sales department to obtain a Return Authorization Number (RAN) prior to return of a product under the terms of this warranty. Notification is to include the Model and Serial numbers of the product along with full details of the problem. Modules returned should clearly show the RAN on the outside of the package.

AMENDMENT NOTICE

C&H Engineering, Inc. makes every attempt to provide up-to-date manuals with the associated equipment. Occasionally, changes are made to the equipment wherein it is necessary to provide amendments to the manual. If any amendments are provided for this manual they are printed on colored paper and will be found at the rear of this manual.

NOTE

The contents of any amendment may affect operation, maintenance, or calibration of the equipment.

INTRODUCTION

This manual describes the functional operation of the C&H Model VX461C VXI 16-Channel Frequency Source (Part No. 11026700). This module is one of a number of test and data acquisition/control modules in the VME and VXI format provided by C&H.

Contained within this manual is information on the physical and electrical specifications, installation and startup procedures, operating procedures, functional analysis, and figures and diagrams required to adequately support this product.

TABLE OF CONTENTS

1.0 GENERAL DESCRIPTION	1
1.1 PURPOSE OF EQUIPMENT.....	1
1.2 SPECIFICATIONS OF EQUIPMENT	1
1.2.1 Key Specifications	1
1.2.2 Electrical	1
1.2.3 Mechanical.....	1
1.2.4 Environmental	2
1.2.5 Bus Compliance	2
2.0 INSTALLATION	3
2.1 UNPACKING AND INSPECTION	3
2.2 HANDLING PRECAUTIONS	3
2.3 INSTALLATION.....	3
2.4 PREPARATION FOR RESHIPMENT	3
3.0 FUNCTIONAL DESCRIPTION	5
3.1 GENERAL	5
3.2 LOGICAL ADDRESS.....	5
3.3 INDICATORS	5
3.4 CONNECTORS	6
3.4.1 Front Panel Connectors	6
3.4.2 Rear Connectors.....	6
3.5 CONFIGURATION REGISTERS.....	7
3.5.1 VXI Configuration Registers	7
3.5.2 Function Source Registers	9
4.0 OPERATING INSTRUCTIONS.....	11
4.1 NORMAL OPERATION	11
5.0 TROUBLE ANALYSIS.....	13
APPENDIX A - BOARD LAYOUT	1
APPENDIX B - CONNECTORS.....	1

LIST OF FIGURES

Figure 1. Functional Block Diagram	5
Figure 2. Hardware Configurable Controls	6
Figure 3. Front Panel.....	7
Figure 4. VXI Configuration Registers	8
Figure 5. General Control/Status Register	9
Figure 6. Period Count Register	9
Figure 7. Range Select Register.....	10
Figure B-1. P1 Pin Configuration	1
Figure B-2. P2 Pin Configuration	2
Figure B-3. Front Panel Connector.....	3

LIST OF TABLES

Table 1. VXI Register Address Map.....	8
--	---

1.0 GENERAL DESCRIPTION

The VX461C is a C-size VXIbus compatible 16-channel square wave frequency source module. The module features 16 independent square wave sources that allow clean on-the-fly frequency changes. Each CMOS-compatible differential output is programmable from 15.26 millihertz to 10 Megahertz.

1.1 PURPOSE OF EQUIPMENT

This module is well suited for applications within automated test equipment and hardware-in-the-loop simulation systems, as well as development laboratory environments.

1.2 SPECIFICATIONS OF EQUIPMENT

1.2.1 Key Specifications

- 16 Independent Square Wave Sources
- Frequency programmable from 15.26 mHz to 10 MHz
- On-the-fly frequency change with no undesirable transitions during range or period changes
- Differential CMOS outputs
- Read back capability on all registers

1.2.2 Electrical

The module only requires the +5V supply from the VXI backplane. The peak module current (I_{PM}) is 1.5 amps.

The output drivers have the following electrical characteristics:

Driver Type:	74HCT245
V_{OH}	$4.9V - (150 \times I_{LOAD}) V$
V_{OL}	$0.1V + (150 \times I_{LOAD}) V$
I_{OH}	-30 mA max.
I_{OL}	30 mA max.

Note: All outputs have 150 ohm series current limiting resistors.

1.2.3 Mechanical

The mechanical dimensions of the module are in conformance with the VXIbus specification Rev 1.4 for single slot size 'C' modules. The nominal dimensions are 233.35 (9.187 in) high x 340 mm (13.386 in) deep.

1.2.4 Environmental

The environmental specifications of the module are:

Operating Temperature:	0°C to +55°C
Storage Temperature:	-40°C to +75°C
Humidity:	<95% without condensation

1.2.5 Bus Compliance

The module complies with the VXIbus Specification Revision 1.4 for C-size register based modules and with VMEbus Specification ANSI/IEEE STD 1014-1987, IEC 821 and IEC 822.

Manufacturer ID:	FC1 hex
Model Code:	FF8 hex
Access Type:	Register Based
Addressing:	A16
Data Transfer:	D16
Sysfail:	not supported
Interrupts:	not supported (IACKIN tied to IACKOUT)
Bus Arbitration:	BRx tied to BGx
Local Bus:	not used

2.0 INSTALLATION

2.1 UNPACKING AND INSPECTION

In most cases the VX461C is individually sealed and packaged for shipment. Verify that there has been no damage to the shipping container. If damage exists then the container should be retained as it will provide evidence of carrier caused problems. Such problems should be reported to the carrier immediately as well as to C&H. If there is no damage to the shipping container, carefully remove the module from its box and anti static bag and inspect for any signs of physical damage. If damage exists, report immediately to C&H.

2.2 HANDLING PRECAUTIONS

The VX461C contains components that are sensitive to electrostatic discharge. When handling the module for any reason, do so at a static-controlled workstation, whenever possible. At a minimum, avoid work areas that are potential static sources, such as carpeted areas. Avoid unnecessary contact with the components on the module.

2.3 INSTALLATION

CAUTION: Read the entire User's Manual before proceeding with the installation and application of power.

Set or verify the module's logical address. Insert the module into the appropriate slot according to the desired priority. Apply power. If no obvious problems exist, proceed to communicate with the module as outlined in Section 4.0 (Operating Instructions).

2.4 PREPARATION FOR RESHIPMENT

If the module is to be shipped separately it should be enclosed in a suitable water and vapor proof anti static bag. Heat seal or tape the bag to insure a moisture-proof closure. When sealing the bag, keep trapped air volume to a minimum.

The shipping container should be a rigid box of sufficient size and strength to protect the equipment from damage. If the module was received separately from a C&H system, then the original module shipping container and packing material may be re-used if it is still in good condition.

3.0 FUNCTIONAL DESCRIPTION

3.1 GENERAL

The VXI-compatible VX461C is configured, controlled, and stasured through on-board registers accessible through the VXI backplane. The frequency of each source output is controlled by writing to a range and period register. To ensure clean on-the-fly frequency change operation, the range value is only accepted when the period register is written. This ensures that a new range value does not affect the frequency of the current output.

A functional block diagram of the module is shown in Figure 1.

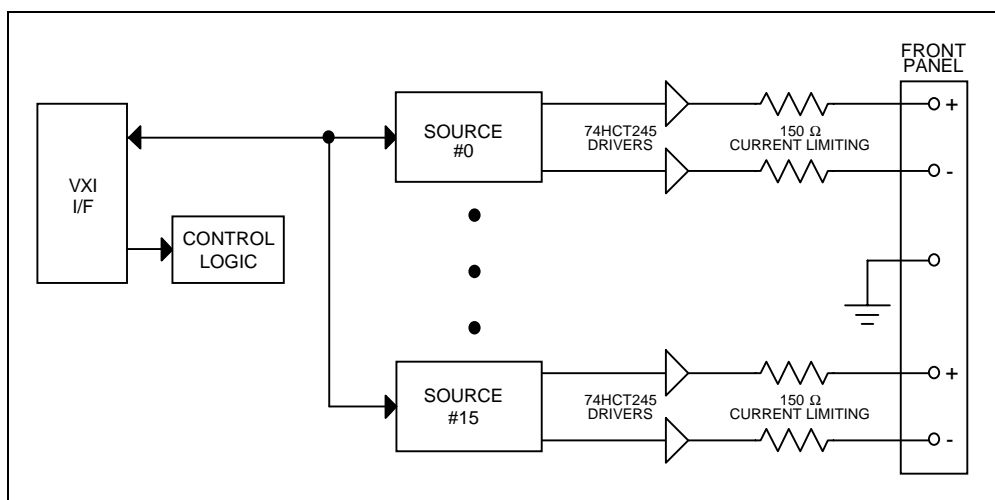

Figure 1. Functional Block Diagram

3.2 LOGICAL ADDRESS

An 8-bit logical address switch is provided to uniquely identify the module in the system. The switch location is shown in Figure 2. The layout is shown with the shield removed, however, the logical address may be configured without removing the shield.

3.3 INDICATORS

Two LED indicators are provided on the front panel. One indicates access to the MODID, the other indicates the BD_SEL status.

MODID: This front panel LED illuminates whenever the host processor applies the MODID signal to the slot the module is occupying.

BD_SEL: This front panel LED illuminates whenever the module is properly accessed by the host processor.

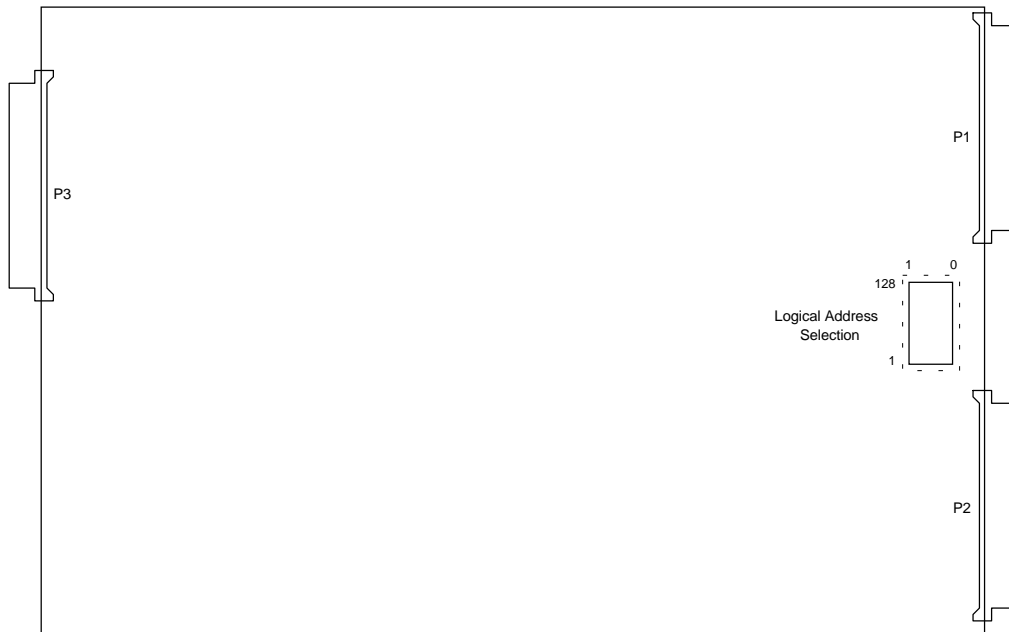

Figure 2. Hardware Configurable Controls

3.4 CONNECTORS

3.4.1 Front Panel Connectors

Source outputs are available through one 96 pin DIN 41612 plug (male) type connector located on the front panel of the module. The connector mates to any 96 pin DIN41612 receptacle, such as the 3M IDC connector part number 3M-62-C-64. The differential outputs are provided on columns A and C with grounds in between each output and on a column B pins. The front panel is shown in Figure 3 and the complete pin definitions is shown in Appendix B. Note that pin A1 of the front panel connector is located in the bottom left corner if viewing the module as shown in Figure 3.

3.4.2 Rear Connectors

3.4.2.1 P1 Connector

The P1 connector is configured in accordance with the VXI P1 specification. (See Appendix B)

3.4.2.2 P2 Connector

The P2 connector is configured in accordance with the VXI P2 specification (See Appendix B).

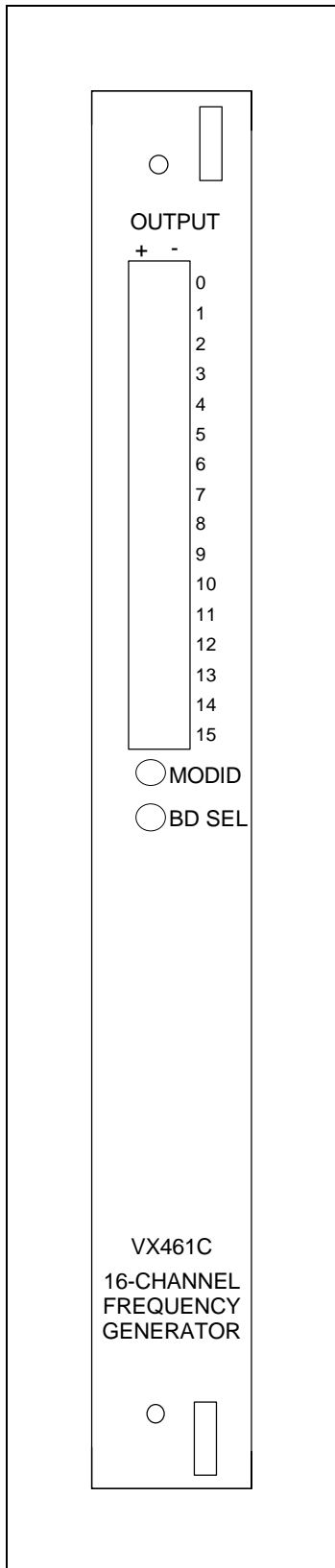

Figure 3. Front Panel

3.5 CONFIGURATION REGISTERS

There are several types of registers used to configure and control the VX461C. The VXI configuration registers provide for control and status as required by the VXIbus specification. The General Status/Control register provides board-level control and status and the Port Register(s) provides port level control and status. An address map of the registers is shown in Table 1 .

3.5.1 VXI Configuration Registers

The VXI configuration registers contain basic information needed to configure a VXIbus system. The configuration information includes: manufacturer identification, product model code, device type, memory requirements, device status, and device control. The registers are briefly described below and are detailed in Figure 4.

VXI Identification (ID) Register (Base + 00h) - A read of this register provides manufacturer identification, device classification (i.e., register based), and the addressing mode (A16). A write to this register has no effect.

VXI Device Type Register (Base + 02h) - A read of this register provides the model code identifier. A write to this register has no effect.

VXI Status/Control Register (Base + 04h) - A read of this register provides the state of P2 MODID* line, and the Ready and self-test Passed status. A write to bit 0 of this register provides a reset of the module. SYSFAIL* is not implemented on this module.

Table 1. VXI Register Address Map

A16 Address	Write Register Description	Read Register Description
Base + 0C	Range Select Register	Range Select Register
Base + 0A	Period Count Register	Period Count Register
Base + 08	General Control Register	General Status Register
Base + 06	VXI Unused Register	VXI Unused Register
Base + 04	VXI Control Register	VXI Status Register
Base + 02	VXI Read Only Register	VXI Device Type Register
Base + 00	VXI Read Only Register	VXI ID Register
Bit	D15 D00	D15 D00

00		VXI ID															
Bit		15	14	13	12	11	10	9	8	7	6	5	4	3	2	1	0
Write		Not Used								Not Used							
Read		Device Class	Address Space	Manufacturer ID													

Device Class ⇒ Device Class (Register Based = binary 11)
 Address Space ⇒ Address Space (A16 Only = binary 11)
 Manuf. ID ⇒ Manufacturer Identification (C & H Engineering = hex FC1)

02		VXI DEVICE TYPE															
Bit		15	14	13	12	11	10	9	8	7	6	5	4	3	2	1	0
Write		Not Used															
Read		1	1	1	1	Model Code											

Model Code ⇒ Model code (C&H Model VX461C = hex FF8)

04		VXI Status/Control															
Bit		15	14	13	12	11	10	9	8	7	6	5	4	3	2	1	0
Write		Not Used															Rst
Read		0	MOD ID*	1	1	1	1	1	1	0	0	0	0	Rdy	Pass	1	1

Rst ⇒ Reset (a 1 resets the card)
 MOD ID* ⇒ Module ID Status (0 = P2 MODID* line is selected (active-high))
 Rdy ⇒ Ready (1 = ready)
 Pass ⇒ Self-test pass/fail indicator (1 = passed)

Figure 4. VXI Configuration Registers

3.5.2 Function Source Registers

General Control/Status Register (08) This register selects which signal source is controlled by writes to the Period Count and Range Select registers. See Figure 5.

08	GENERAL CONTROL/STATUS															
Bit	15	14	13	12	11	10	9	8	7	6	5	4	3	2	1	0
Write	Not Used												Source Select			
Read	Not Used												Source Select			

Source Select \Rightarrow Selects Source 0 through 15

Figure 5. General Control/Status Register

Period Count Register (0A) This read/write register controls the period of the output waveform. The resulting period is equal to the count times the period range value previously set in the Range Register. Period counts of 0 and 1 are not valid. The new period (frequency) will begin at the next transition of the current cycle. For example, if at the time of the write to this register, the output waveform is at a low (0) logic level, the new period (frequency) will begin at the next high transition for the current period. Note that a write to this register causes the period count and period range to be applied. If the period range register is changed, you must write to the Period Count register before the new range is accepted.

0A	PERIOD COUNT REGISTER															
Bit	15	14	13	12	11	10	9	8	7	6	5	4	3	2	1	0
Write	Period Count															
Read	Period Count															

Period Count \Rightarrow Period = Period Count X Range Select Value (Frequency = 1 / Period)

Note: The minimum value is 2. An entry of 0 or 1 may produce unpredictable results.

Figure 6. Period Count Register

Range Select Register (0C) This read/write register selects the desired period range and runs/stops the output as detailed in Figure 7. When output is stopped by setting the RUN bit to a 0, the differential output goes to a low (0) logic state (i.e., the + is low, and the - is high). When changing the period range, note that the new range is not applied until a period count is written.

		RANGE SELECT REGISTER																
OC	Bit	15	14	13	12	11	10	9	8	7	6	5	4	3	2	1	0	
	Write	Not Used												Run	Range Select			
	Read	Not Used												Run	Range Select			

Run ⇒ Run/Stop (1 = run (On), 0 = stop (Off))

Range Select ⇒ Period Range Selection	bit	<u>2</u>	<u>1</u>	<u>0</u>	<u>Period</u>	<u>Frequency Range</u>
	0	0	0	0	50 ns	305.2 Hz to 10 Mhz
	0	0	1	1	100 ns	152.6 Hz to 5 Mhz
	0	1	0	0	1 μs	15.26 Hz to 500 Khz
	0	1	1	1	10 μs	1.526 Hz to 50 Khz
	1	0	0	0	100 μs	152.6 mHz to 5 Khz
	1	0	1	1	1 ms	15.26 mHz to 500 Hz
	1	1	0	0	invalid	
	1	1	1	1	invalid	

Note: You must subsequently write to the Period Register to cause the RUN and Range Select values to be applied.

Figure 7. Range Select Register

4.0 OPERATING INSTRUCTIONS

4.1 NORMAL OPERATION

Prior to installation, the module's logical address must be set. The logical address has a range of 0 to 255. Any value within this range is valid, but care should be taken not to set the logical address the same as another module in the system. Position 1 on the switch (marked 128 on the shield) is the most significant bit and has a weighted value of 128 when the switch is in the off position (marked 1 on shield). Position 8 on the switch (marked 1 on the shield) is the least significant bit and has a weighted value of 1 when the switch is in the off position. The sum of the weighted values of all the switches in the off position (marked 1 on the shield) is the module's logical address. The VXI secondary address is the logical address divided by 8.

After installation and power-up, configure the General Status/Control Register to the desired signal source. Set the period range using the Range Select Register. Then set the period count using the Period Count register. The output waveform will start if the RUN bit in the Range Select register was set to a 1. The output waveform always starts on the logic low level of the cycle. For periods with long (> 1 second) cycles, this may be deceiving, since a change in the output will not take place until half of the period has expired.

The VXI Configuration Registers do not require any setup.

5.0 TROUBLE ANALYSIS

If a bus error or bus time-out error occurs, verify that the logical address switch is properly set. Verify correct program addressing and word size.

If a signal source does not respond, utilize the modules read back capability to verify that the source's registers are correctly set. Verify that the Period Register is written after every write to the Range Select register, even if only the RUN bit was changed. When diagnosing output problems, isolate the module from external loads by removing the connector.

APPENDIX A - BOARD LAYOUT

Insert Board Layout Here

APPENDIX B - CONNECTORS

PIN	C	B	A
1	D08	-	D00
2	D09	-	D01
3	D10	-	D02
4	D11	BG0IN*	D03
5	D12	BG0OUT*	D04
6	D13	BG1IN*	D05
7	D14	BG10UT*	D06
8	D15	BG2IN*	D07
9	GND	BG20UT*	GND
10	-	BG3IN*	-
11	-	BG3OUT*	-
12	SYSRESET*	-	DS1*
13	LWORD*	-	DS0*
14	AM5	-	WRITE*
15	A23	-	-
16	A22	AM0	DTACK*
17	A21	AM1	-
18	A20	AM2	-
19	A19	AM3	-
20	A18	GND	IACK*
21	A17	-	IACKIN*
22	A16	-	IACKOUT*
23	A15	GND	AM4
24	A14	IRQ7*	A07
25	A13	IRQ6*	A06
26	A12	IRQ5*	A05
27	A11	IRQ4*	A04
28	A10	IRQ3*	A03
29	A09	IRQ2*	A02
30	A08	IRQ1*	A01
31	+12 V	-	-12 V
32	+5 V	+5 V	+5 V

Figure B-1. P1 Pin Configuration

PIN	C	B	A
1	-	+5V	-
2	-	GND	-
3	-	-	-
4	-	-	GND
5	-	-	-
6	-	-	-
7	GND	-	-
8	-	-	-
9	-	-	-
10	GND	-	GND
11	-	-	-
12	-	GND	-
13	-	+5V	-
14	-	-	-
15	-	-	-
16	GND	-	GND
17	-	-	-
18	-	-	-
19	-	-	-
20	-	-	-
21	-	-	-
22	GND	GND	GND
23	-	-	-
24	-	-	-
25	-	-	-
26	-	-	-
27	-	-	-
28	GND	-	-
29	-	-	-
30	GND	-	MODID
31	-	GND	GND
32	-	+5V	-

Figure B-2. P2 Pin Configuration

PIN	A	B	C
32	Source 0+	Gnd	Source 0-
31	Gnd	Gnd	Gnd
30	Source 1+	Gnd	Source 1-
29	Gnd	Gnd	Gnd
28	Source 2+	Gnd	Source 2-
27	Gnd	Gnd	Gnd
26	Source 3+	Gnd	Source 3-
25	Gnd	Gnd	Gnd
24	Source 4+	Gnd	Source 4-
23	Gnd	Gnd	Gnd
22	Source 5+	Gnd	Source 5-
21	Gnd	Gnd	Gnd
20	Source 6+	Gnd	Source 6-
19	Gnd	Gnd	Gnd
18	Source 7+	Gnd	Source 7-
17	Gnd	Gnd	Gnd
16	Source 8+	Gnd	Source 8-
15	Gnd	Gnd	Gnd
14	Source 9+	Gnd	Source 9-
13	Gnd	Gnd	Gnd
12	Source 10+	Gnd	Source 10-
11	Gnd	Gnd	Gnd
10	Source 11+	Gnd	Source 11-
9	Gnd	Gnd	Gnd
8	Source 12+	Gnd	Source 12-
7	Gnd	Gnd	Gnd
6	Source 13+	Gnd	Source 13-
5	Gnd	Gnd	Gnd
4	Source14+	Gnd	Source14-
3	Gnd	Gnd	Gnd
2	Source 15+	Gnd	Source 15-
1	Gnd	Gnd	Gnd

Figure B-3. Front Panel Connector

NOTES

READER'S COMMENT FORM

Your comments assist us in improving the usefulness of C&H's publications; they are an important part of the inputs used for revision.

C&H Engineering, Inc. may use and distribute any of the information that you supply in any way that it believes to be appropriate without incurring any obligation whatsoever. You may, of course, continue to use the information which you supply.

Please refrain from using this form for technical questions or for requests for additional publications; this will only delay the response. Instead, please direct your technical questions to your authorized C&H representative.

COMMENTS:

Thank you for helping C&H to deliver the best possible product. Your support is appreciated.

Sincerely,

F.R.Harrison
President and CEO

INSTRUCTIONS

In its continuing effort to improve documentation, C&H Engineering, Inc. provides this form for use in submitting any comments or suggestions that the user may have. This form may be detached, folded along the lines indicated, taped along the loose edge (DO NOT STAPLE), and mailed. Please try to be as specific as possible and reference applicable sections of the manual or drawings if appropriate. Also, indicate if you would like an acknowledgment mailed to you stating whether or not your comments were being incorporated.

NOTE: This form may not be used to request copies of documents or to request waivers, deviations, or clarification of specification requirements on current contracts. Comments submitted on this form do not constitute or imply authorization to waive any portion of the referenced document(s) or to amend contractual requirements.

————— (Fold along this line) —————

————— (Fold along this line) —————

Place Stamp Here

C&H Engineering, Inc.
Technical Publications
P. O. Box 14765
Austin, Texas 78761-4765

