

M76 – Digital Multimeter

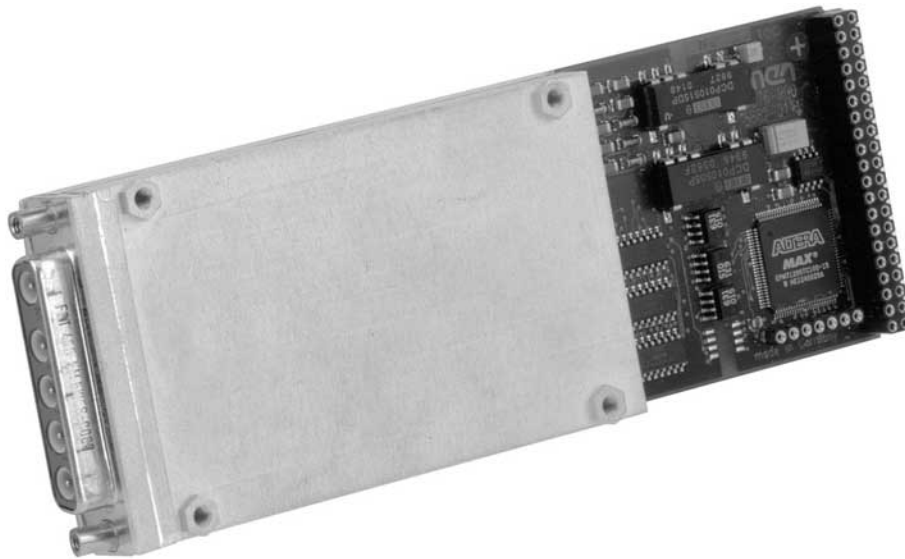

User Manual

**Board-Level Computers
for Industrial Applications**

M76 – Digital Multimeter

The M76 M-Module is a digital system multimeter M-Module for acquisition of DC and AC voltage, DC and AC current and resistance through 2- or 4-wire measurement. It is an advanced, more compact version of the M60 M-Module with higher accuracy but without the extreme voltage isolation of the M60.

The M76 is based on a 24-bit Sigma-Delta A/D converter with on-chip notch filter. This technology allows sampling frequencies (or filter frequencies) between 10Hz and 1kHz providing varying resolutions.

Features such as autoranging, limit testing etc. can be implemented by means of software.

Technical Data

Resolution

- 22.5 bits @ 10Hz sampling
- 20 bits @ 50/60 Hz sampling
- 11 bits @ 1kHz sampling

DC Voltage Measurement

- Maximum input voltage if no further safety measures are taken:
 - 60V DC / 42V AC for all measuring ranges
- Maximum input voltage if requirements of EN60950 are fulfilled through additional safety measures (see user manual):
 - High-voltage input: 500V DC for 500V range
 - Normal input: 125V DC for 125mV, 1.25V, 12.5V and 125V range
- Measuring ranges:
 - -125mV..+125mV
 - -1.25V..+1.25V
 - -12.5V..+12.5V
 - -125V..+125V
 - -500V..+500V
- Measuring accuracy:
 - 24 hours, 23°C ±1°C: error < 0.025%
 - 90 days, 23°C ±5°C: error < 0.05%
 - Temperature coefficient 0°C..+55°C: error < 0.01%
- Input impedance:
 - 40MΩ @ 500V input (HV)
 - 10MΩ @ 125V and 12.5V range
 - > 1GΩ @ 1.25V and 125mV range
- Input current: max. 10pA @ 23°C
- CMRR: 100dB @ 50/60Hz
- NMRR: 60dB @ 50/60Hz

AC Voltage Measurement

- Maximum input voltage if no further safety measures are taken:
 - 60V DC / 42V AC for all measuring ranges
- Maximum input voltage if requirements of EN60950 are fulfilled through additional safety measures (see user manual):
 - High-voltage input: 250V AC
 - Normal input: 60V AC
- Sine 40Hz..100Hz
- Measuring ranges:
 - 250mV RMS
 - 2.5V RMS
 - 25V RMS
 - 250V RMS (high-voltage input)
- Crest factor: max. 4
- Measuring accuracy:
 - 24 hours, 23°C ±1°C: error < 0.5%
 - 90 days, 23°C ±5°C: error < 1%
 - Range error < 1%
- Input impedance:
 - High-voltage input: 40MΩ
 - Normal input: 1MΩ
- Input current: max. 10pA @ 23°C
- CMRR: 100dB @ 50/60Hz

DC Current Measurement

- Maximum input voltage if no further safety measures are taken:
 - 60V DC for all measuring ranges
- Measuring ranges:
 - -12.5mA..+12.5mA
 - -125mA..+125mA
 - -1.25A..+1.25A
 - -2.5A..+2.5A
- Measuring accuracy:
 - 24 hours, 23°C ±1°C: error < 0.025%
 - 90 days, 23°C ±5°C: error < 0.05%
 - Temperature coefficient 0°C..+55°C: error < 0.01%
- Shunt:
 - 1Ω @ 12.5mA, 125mA range
 - 0.1Ω @ 1.25A, 2.5A range

AC Current Measurement

- Maximum input voltage if no further safety measures are taken:
 - 42V AC for all measuring ranges
- Sine 40Hz..100Hz

- Measuring ranges:
 - 25mARMS
 - 250mARMS
 - 2.5ARMS
- Crest factor: max. 4
- Measuring accuracy:
 - 24 hours, 23°C ±1°C: error < 0.5%
 - 90 days, 23°C ±5°C: error < 1%
 - Range error < 1%
- Shunt:
 - 1Ohm @ 25mA, 250mA range
 - 0.1Ohm @ 2.5A range

Resistance Measurement

- Measuring ranges:
 - 250Ohm
 - 2.5kOhm
 - 25kOhm
 - 250kOhm
 - 2.5MOhm
- Measuring accuracy 250Ohm, 2.5kOhm, 25kOhm, 250kOhm:
 - 24 hours, 23°C ±1°C: error < 0.1%
 - 90 days, 23°C ±5°C: error < 0.2%
 - Temperature coefficient 0°C..+55°C: error < 0.01%
- Measuring accuracy 2.5MOhm:
 - 24 hours, 23°C ±1°C: error < 1%
 - 90 days, 23°C ±5°C: error < 2%
 - Temperature coefficient 0°C..+55°C: error < 0.1%
- Measuring modes: 2- and 4-wire
- Maximum measuring voltage: 2.5V

Peripheral Connections

- Via front panel on a 5-pin 5W5S D-Sub receptacle connector with high-voltage contacts (recommended)
- Via carrier-board connector (rear-panel I/O) (not recommended)

M-Module Characteristics

- A08, D16, INTA, IDENT

Electrical Specifications

- Isolation voltage:
 - 500V DC between isolated side and digital side
 - 180V DC COM to shield
 - Voltage between the connector shield and isolated ground is limited to 180V using a varistor; AC coupling between connector shield and isolated ground through 47nF capacitor

- Supply voltage/power consumption: +5V (4.85V..5.25V), 700mA max.
- MTBF: 100,000h @ 50°C

Mechanical Specifications

- Dimensions: conforming to M-Module Standard
- Weight: 94g

Environmental Specifications

- Temperature range (operation):
 - 0..+60°C or -40..+85°C
 - Airflow: min. 10m³/h
- Temperature range (storage): -40..+85°C
- Relative humidity (operation): max. 95% non-condensing
- Relative humidity (storage): max. 95% non-condensing
- Altitude: -300m to + 3,000m
- Shock: 15g/0.33ms, 6g/6ms
- Vibration: 1g/5..2,000Hz

Safety

- THE M76 DOES NOT COMPLY WITH THE REQUIREMENTS OF THE EN60950 STANDARD. THE MAXIMUM INPUT VOLTAGES FOR ALL TYPES OF MEASUREMENTS ARE 60V DC AND 42V AC. HOWEVER, THE M76 WAS DESIGNED TO PROVIDE HIGH-VOLTAGE FUNCTIONALITY. IF YOU NEED TO APPLY VOLTAGES HIGHER THAN 60V DC AND 42V AC, TAKE APPROPRIATE MEASURES TO KEEP THE SAFETY REQUIREMENTS OF EN60950.
- PCB manufactured with a flammability rating of 94V-0 by UL recognized manufacturers

EMC

- Tested according to EN 55022 / 1999-05 (radio disturbance) and EN 55024 / 1999-05 (immunity) with regard to CE conformity

Software Support

- MEN Driver Interface System (MDIS)

Block Diagram

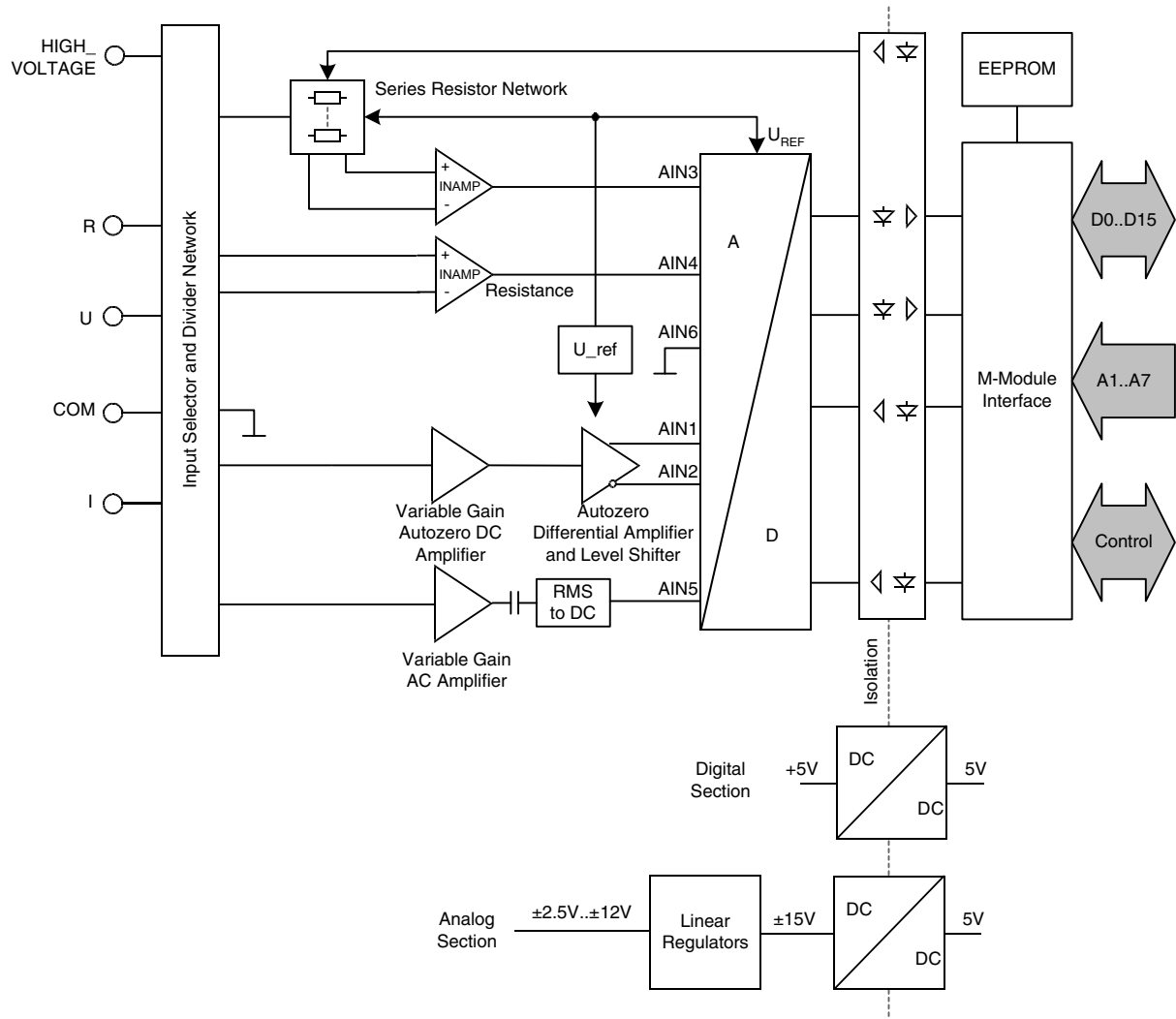

Product Safety



Input Voltage Restrictions

For reasons of space, the M76 does not comply with the requirements of the EN60950 standard. Therefore the maximum input voltages for all types of measurements are 60V DC and 42V AC.

However, the M76 was designed to provide high-voltage functionality. If you need to apply voltages higher than 60V DC and 42V AC, you must take appropriate measures to keep the safety requirements of EN60950.

MEN does not assume any liability arising out of the application or use of the M76, and specifically disclaims any and all liability, including without limitation consequential or incidental damages.



Fuses

This board contains fuses. If you need to replace a fuse, make sure you adhere to the following types and ratings:

| Component | Current Rating | Type | Size |
|-----------|----------------|------|----------|
| S1 | 1.5A | Fast | SMT 1206 |
| S2 | 1.5A | Fast | SMT 1206 |
| S3 | 1.5A | Fast | SMT 1206 |
| S4 | 1.5A | Fast | SMT 1206 |

For component locations, see [Chapter 5.3 Component Plans](#) on page 38.



Electrostatic Discharge (ESD)

Computer boards and components contain electrostatic sensitive devices. Electrostatic discharge (ESD) can damage components. To protect the board and other components against damage from static electricity, you should follow some precautions whenever you work on your computer.

- Power down and unplug your computer system when working on the inside.
- Hold components by the edges and try not to touch the IC chips, leads, or circuitry.
- Use a grounded wrist strap before handling computer components.
- Place components on a grounded antistatic pad or on the bag that came with the component whenever the components are separated from the system.
- Store the board only in its original ESD-protected packaging. Retain the original packaging in case you need to return the board to MEN for repair.

About this Document

This user manual describes the hardware functions of the board, connection of peripheral devices and integration into a system. It also provides additional information for special applications and configurations of the board.

The manual does not include detailed information on individual components (data sheets etc.). A list of literature is given in the appendix.

History

| Edition | Description | Technical Content | Date of Issue |
|----------------|--------------------|--------------------------|----------------------|
| E1 | First edition | Jürgen Oelschlegel | 2000-12-20 |
| E2 | Second edition | Manfred Schmitz | 2001-08-14 |
| E3 | Third edition | Frank Bodammer | 2003-02-11 |

Conventions



This sign marks important notes or warnings concerning proper functionality of the product described in this document. You should read them in any case.

italics

Folder and file names are printed in *italics*.

bold

Bold type is used for emphasis.

hyperlink

Hyperlinks are printed in [blue color](#).



The globe will show you where [hyperlinks](#) lead directly to the Internet, so you can look for the latest information online.

0xFF

Hexadecimal numbers are preceded by "0x", which is the usual C-language convention, and are printed in a monospace type, e.g. 0x00FFFF.

IRQ#
/IRQ

Signal names followed by "#" or preceded by a slash ("/") indicate that this signal is either active low or that it becomes active at a falling edge.

in/out

Signal directions in signal mnemonics tables generally refer to the corresponding board or component, "in" meaning "to the board or component", "out" meaning "coming from it".



Vertical lines on the outer margin signal technical changes to the previous edition of the document.

Copyright Information

MEN reserves the right to make changes without further notice to any products herein. MEN makes no warranty, representation or guarantee regarding the suitability of its products for any particular purpose, nor does MEN assume any liability arising out of the application or use of any product or circuit, and specifically disclaims any and all liability, including without limitation consequential or incidental damages.

"Typical" parameters can and do vary in different applications. All operating parameters, including "Typicals" must be validated for each customer application by customer's technical experts.

MEN does not convey any license under its patent rights nor the rights of others.

MEN products are not designed, intended, or authorized for use as components in systems intended for surgical implant into the body, or other applications intended to support or sustain life, or for any other application in which the failure of the MEN product could create a situation where personal injury or death may occur. Should Buyer purchase or use MEN products for any such unintended or unauthorized application, Buyer shall indemnify and hold MEN and its officers, employees, subsidiaries, affiliates, and distributors harmless against all claims, costs, damages, and expenses, and reasonable attorney fees arising out of, directly or indirectly, any claim of personal injury or death associated with such unintended or unauthorized use, even if such claim alleges that MEN was negligent regarding the design or manufacture of the part.

All brand or product names are trademarks or registered trademarks of their respective holders.

Information in this document has been carefully checked and is believed to be accurate as of the date of publication; however, no responsibility is assumed for inaccuracies. MEN will not be liable for any consequential or incidental damages arising from reliance on the accuracy of this document. The information contained herein is subject to change without notice.

Copyright © 2003 MEN Mikro Elektronik GmbH. All rights reserved.



Germany

MEN Mikro Elektronik GmbH
Neuwieder Straße 7
90411 Nuremberg
Phone +49-911-99 33 5-0
Fax +49-911-99 33 5-99
E-mail info@men.de
www.men.de

France

MEN Mikro Elektronik SA
18, rue René Cassin
ZA de la Châtelaine
74240 Gaillard
Phone +33 (0) 450-955-312
Fax +33 (0) 450-955-211
E-mail info@men-france.fr
www.men-france.fr

UK

MEN Micro Ltd
Whitehall, 75 School Lane
Hartford, Northwich
Cheshire UK, CW8 1PF
Phone +44 (0) 1477-549-185
Fax +44 (0) 1477-549-178
E-mail info@menmicro.co.uk
www.menmicro.co.uk

USA

MEN Micro, Inc.
3740 North Josey Lane, Suite 203
Carrollton, TX 75007
Phone 972-939-2675
Fax 972-939-0055
E-mail sales@menmicro.com
www.menmicro.com

Contents

| | | |
|----------|---|-----------|
| 1 | Getting Started | 13 |
| 1.1 | Integrating the M-Module into a System | 13 |
| 1.2 | Installing Driver Software | 13 |
| 1.3 | Power Supply | 13 |
| 2 | Connecting the M-Module | 14 |
| 2.1 | Peripheral Interface | 14 |
| 2.2 | Host Interface | 15 |
| 3 | Address Organization | 16 |
| 4 | Functional Description | 17 |
| 4.1 | A/D Converter | 17 |
| 4.1.1 | Registers of the A/D Converter | 17 |
| 4.2 | Configuring the M-Module | 21 |
| 4.3 | Making Measurements | 23 |
| 4.3.1 | DC Voltage Measurement | 23 |
| 4.3.2 | AC Voltage Measurement | 24 |
| 4.3.3 | DC Current Measurement | 25 |
| 4.3.4 | AC Current Measurement | 25 |
| 4.3.5 | Resistance Measurement | 26 |
| 4.4 | Reading Measuring Data | 29 |
| 4.5 | M-Module Control Options | 31 |
| 4.6 | M-Module Identification and User EEPROM | 32 |
| 4.6.1 | Data Structure in the User EEPROM | 32 |
| 5 | Appendix | 36 |
| 5.1 | Literature and WWW Resources | 36 |
| 5.2 | Board Revisions | 36 |
| 5.3 | Component Plans | 37 |

Figures

| | |
|---|----|
| Figure 1. ADC Register Arrangement | 17 |
| Figure 2. Measuring Principle of Resistance Measurements | 26 |
| Figure 3. 2-Wire Resistance Measurement | 27 |
| Figure 4. 4-Wire Resistance Measurement | 28 |
| Figure 5. Application Example: Strain Gage Measurements with 4-Wire Connection | 28 |
| Figure 6. Component Plan of M76 Hardware Revision 02 - Top side | 37 |
| Figure 7. Component Plan of M76 Hardware Revision 02 - Bottom side | 37 |

Tables

| | | |
|-----------|---|----|
| Table 1. | Pin Assignment of the 5-Pin D-Sub Connector | 14 |
| Table 2. | Signal Mnemonics of Peripheral Connectors | 14 |
| Table 3. | Supported Pins of 60-Pin Plug Connector on Carrier Board | 15 |
| Table 4. | Address Map | 16 |
| Table 5. | Register Selection of ADC | 18 |
| Table 6. | Applicable Channels of the ADC | 21 |
| Table 7. | Setting a Measuring Mode through the Configuration Register | 22 |
| Table 8. | Selecting the Series Resistance for Resistance Measurement | 27 |
| Table 9. | Factory Setting of Calibration Values in the User EEPROM | 33 |
| Table 10. | Table of Hardware Revisions | 36 |

1 Getting Started

This chapter will give some hints for first installation in a system as a "check list".

1.1 Integrating the M-Module into a System

You can use the following "check list" to install the M-Module on a carrier board for the first time and to test proper functioning of the board.



The M-Module is completely trimmed on delivery.



Always use a carrier board that suits your M76 model, i.e. with or without 24-pin board-to-board connectors, respectively. See also [Chapter 2.1 Peripheral Interface on page 12](#).



Note: If your carrier board has 24-pin board-to-board M-Module connectors, you will have difficulties mounting the M-Module as usual. You will need to remove the front panel properly, then install the M-Module and reinstall the front panel. Please refer to the carrier board's hardware manual or turn to the respective vendor for more information.

- Power-down the system.
- Install the M-Module carrier board in your system without the M-Module.
- Power-up the system.
- Test the carrier board.
- If O.K., power-down the system and remove the carrier board.
- Install the M-Module in slot 0 of the carrier board.
- Insert the carrier board into the system again.
- Power-up the system.
- Load a suitable debugger.
- Access the base address plus $0 \times FE$, reading a word.
- If a bus error is occurring now, the M-Module is not plugged properly or the carrier board is not set up correctly (e. g. D201 PLD must be loaded). Please refer to the carrier board's user manual for details.
- No further testing is possible at this point, since complex software would be needed to do this.

1.2 Installing Driver Software

For a detailed description on how to install driver software please refer to the M-Module's software user manual.



You can find any driver software available for download on MEN's [website](#).

1.3 Power Supply

Power supply to the M-Module is done via the carrier board. The necessary voltage is +5V @ 5% with a typical power consumption of 0.7A.

2 Connecting the M-Module

2.1 Peripheral Interface

There are two possibilities for connecting peripherals:

- Connection via 5-pin 5W5S mixed-layout D-Sub connector (recommended) or
- Connection via the carrier board (not recommended).

Because of the very high susceptibility of the circuitry to electromagnetic interferences, the M76's analog section is encapsulated in a metal housing. For high-accuracy measurements of small signals the use of shielded cables at the front-panel D-Sub input is highly recommended. A suitable mating connector is available from MEN (see MEN's [website](#)).



The 24-pin connector for rear I/O was implemented as a user option. It is not mounted by standard. However, MEN offers models of the M76 with the 24-pin connector mounted, and therefore with a hole in the M-Module's metal housing. **Please be aware that with such an incomplete metal housing the accuracy of the M-Module decreases dramatically.** For details, see [Chapter 2.1.2 Connection via Carrier Board/24-pin Connector on page 14](#). For ordering options, see MEN's [website](#).



For reasons of safety, you should always connect the M-Module to protective ground. To do this, use screws from MEN to mount the M-Module on the carrier board, screw the carrier's front panel to the enclosure so as to be conductive, and ground the enclosure. For suitable screws, see the M76 data sheet on MEN's [website](#).





Table 1. Signal Mnemonics of Peripheral Connectors

| Signal | Direction | Function |
|--------------|-----------|---|
| COM | - | Analog ground |
| HIGH_VOLTAGE | in | High-voltage input for voltage measurements in the 250V AC and 500V DC range |
| I | in | Current input; "Sense Low" input for 4-wire resistance measurement |
| R | out | "Resistance High" for 2-wire resistance measurements; "Measurement Current out" for 4-wire resistance measurement |
| U | in | Voltage input; "Sense High" input for 4-wire resistance measurement |

For a detailed description on how to connect equipment for measurements, please see [Chapter 4.3 Making Measurements on page 24](#).

2.1.1 Connection via 5-pin D-Sub Connector

Table 2. Pin Assignment of the 5-Pin D-Sub Connector

| | | | |
|----|---|----|--------------|
| 1 |  | 1 | I |
| 2 |  | 2 | COM |
| 3 |  | 3 | U |
| 4 |  | 4 | R |
| 5A |  | 5A | HIGH_VOLTAGE |

Connector types:

- 5-pin 5W5 D-Sub mixed-layout receptacle connector with high-voltage contacts, with grounding and bolt UNC4-40, e.g. FCT FM5W5S series
- Mating connector:
5-pin 5W5 D-Sub mixed-layout plug connector, e.g. FCT FM5W5T series



For full M-Module performance use the D-Sub input with appropriate cabling. A suitable mating connector is available from MEN (see [website](#)). Use an M-Module carrier board without 24-pin connectors, if available and/or applicable.



N.B.: If you use a carrier board with 24-pin connectors, voltages will be led through to the backplane in any case. Therefore, the voltage must not exceed 125V. You should check for further restrictions of your host system before you try to make any measurements.

2.1.2 Connection via Carrier Board/24-pin Connector

When a carrier board with a 96-pin DIN 41612 PCB connection is used for peripheral signals (for example a 6U VMEbus board), these are fed to the M-Module through a 24-pin receptacle connector. You can connect up to four 21-pin connectors to the 96-pin connector (cf. carrier board manual). When these connectors are used, for each M-Module three pins of the DIN 41612 PCB connector cannot be used. The pin numbers for the 96-pin connector shown below are valid for M-Module slot number 3. If other M-Module slots (2, 1 or 0) are used, the value 8, 16 or 24 must be added as appropriate.



If the M76 is connected to a standard carrier board via the 24-pin connector for rear I/O, the accuracy of the M-Module decreases dramatically, because a lot of parasitic effects interfere with the measured value. System noise (of the host system) will be coupled into the inputs via the normally unshielded PCB tracks of the carrier board and the system backplane. The current measurement performance will derate because all series resistances of external PCB tracks and board-to-board connectors will be added to the shunt resistor of the M-Module. Especially in the 1.25A and 2.5A range, measured values will be much more distorted than necessary. When measuring large resistances, unknown leakage currents of the host system will bypass the equipment under test (EUT) and falsify the result. When performing voltage measurements (possible up to 125V), you must take care that the limitations of the host system are not exceeded! Be aware that the D-Sub inputs are routed to the corresponding 24-pin carrier connection. External voltages at the D-Sub cabling will therefore be led into the host system, bypassing the M-Module isolation.



N.B.: If you use a carrier board with 24-pin connectors, voltages will be led through to the backplane. Therefore, the voltage must not exceed 125V. You should check for further restrictions of your host system before you try to make any measurements.



N.B.: If you make measurements via the backplane, you should be aware that voltages will also be led through to the D-Sub connector. Take the necessary action to shield the D-Sub connector in a suitable manner, e. g. using a connector cover.



N.B.: Never modify the M-Module's metal housing on your own!

Table 3. Pin Assignment of the 24-Pin Receptacle Connector

| | | | | |
|--|----|-----|----|-----|
| | 23 | - | 24 | - |
| | 21 | - | 22 | - |
| | 19 | R | 20 | R |
| | 17 | - | 18 | - |
| | 15 | U | 16 | U |
| | 13 | - | 14 | - |
| | 11 | COM | 12 | COM |
| | 9 | COM | 10 | COM |
| | 7 | COM | 8 | COM |
| | 5 | I | 6 | I |
| | 3 | I | 4 | I |
| | 1 | I | 2 | I |

Connector types:

- two 12-pin receptacles, high-precision, 2.54mm pitch, for square pins \varnothing 0.635mm gold, 6.9mm height
- mating connector:
two 12-pin plugs, 2.54mm pitch, square pins \varnothing 0.635mm gold

Table 4. Signal Correspondence between 24-Pin M-Module Connector and 96-pin Carrier Board Connector

| | | | | |
|--|---|-----|-----|-----|
| | 1 | I | I | I |
| | 2 | I | I | I |
| | 3 | COM | COM | COM |
| | 4 | COM | COM | COM |
| | 5 | - | - | U |
| | 6 | U | - | - |
| | 7 | R | R | - |
| | 8 | - | - | - |

2.2 Host Interface

The M-Module supports the following signals of a 60-pin carrier board interface plug connector:

Note: Only two rows - A and B - of the 60-pin connector are mounted on the M76!

Table 5. Supported Pins of 60-Pin Plug Connector on Carrier Board

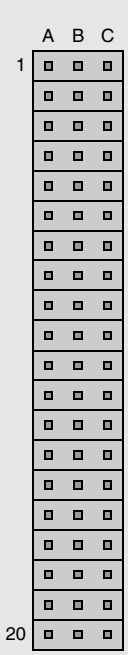
| | | A | B | C |
|--|----|--------|--------|---|
|  | 1 | /CS | GND | - |
| | 2 | A01 | +5V | - |
| | 3 | A02 | +12V | - |
| | 4 | A03 | - | - |
| | 5 | A04 | GND | - |
| | 6 | A05 | - | - |
| | 7 | A06 | - | - |
| | 8 | A07 | GND | - |
| | 9 | D08 | D00 | - |
| | 10 | D09 | D01 | - |
| | 11 | D10 | D02 | - |
| | 12 | D11 | D03 | - |
| | 13 | D12 | D04 | - |
| | 14 | D13 | D05 | - |
| | 15 | D14 | D06 | - |
| | 16 | D15 | D07 | - |
| | 17 | /DS1 | /DS0 | - |
| | 18 | /DTACK | /WRITE | - |
| | 19 | - | /IRQ | - |
| | 20 | /RESET | SYSCLK | - |

Connector types:

- Three 20-pin receptacles, high-precision, 2.54mm pitch, for square pins \varnothing 0.635mm gold, 6.9mm height
- Mating connector:
Three 20-pin plugs, 2.54mm pitch, square pins \varnothing 0.635mm gold

3 Address Organization

When using the driver software supplied, you do not need to be familiar with the hardware of the M-Module in detail. However, familiarity with the address organization of the board is essential if you wish to write your own software for the M-Module or do low-level development.

The 256-byte I/O area of the M-Module is hardware-mapped. The address at which individual functions can be addressed from the carrier board is computed from the base address of the M-Module plus the address in the following table.

Table 6. Address Map

| Address | D15..D8 | D7..D0 |
|---------|--|---|
| 0x00 | Data Register D23..D8 (24-bit access to ADC) (r/w) | |
| 0x02 | Data Register D7..D0 (24-bit access to ADC) (r/w) | - |
| 0x04 | Configuration Register D23..D8 (w) | |
| 0x06 | Configuration Register D7..D0 (w) | - |
| 0x08 | - | Communications Register (8-bit access to ADC registers) (r/w) |
| 0x0A | - | Access Register (w) |
| 0x0C | - | Status Register (r) |
| 0x0E | - | Control Register (w) |
| 0xFE | - | M-Module Identification and User EEPROMs (r/w) |



Note: Please keep in mind that you must make word accesses to any of the above registers!

4 Functional Description

4.1 A/D Converter

The AD7714-5 by ANALOG DEVICES is used for A/D conversion.

The device is a complete analog front end for low frequency measurement applications. It employs a sigma-delta conversion technique to implement up to 24 bits of no-missing-codes performance. The modulator output is processed by an on-chip digital filter. The first notch of this digital filter can be programmed via the on-chip control register allowing adjustment of the filter cutoff and settling time.

The AD7714 features a serial interface that can be configured for three-wire operation. Gain settings, signal polarity and channel selection can be configured via software using the input serial port. The device contains self-calibration, system calibration and background calibration options and also allows the user to read and write the on-chip calibration registers.

4.1.1 Registers of the A/D Converter

The A/D converter (ADC) has eight internal registers of 8 or 24 bits. The device has an input multiplexer for channel selection.

Access to the ADC's registers is through a Communications Register which controls the channel selection, decides whether the next operation is a read or write operation and also decides which register the next read or write operation accesses. All communications to the component must start with a write operation to the Communications Register. After power-on or reset, the device expects a write to its Communications Register.

With read accesses the logic device must be signaled whether an 8-bit or 24-bit transfer is to be performed immediately or after the data ready (*/DRDY*) signal.

Figure 1. ADC Register Arrangement

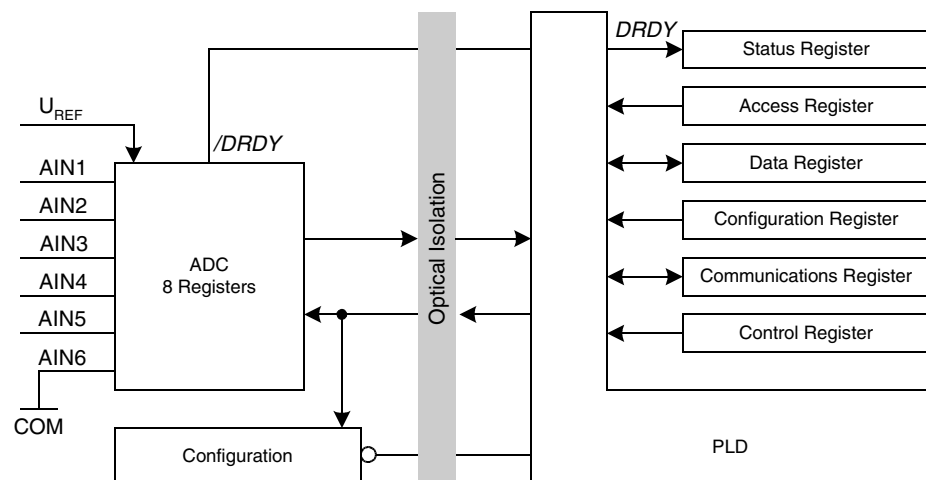

Note: The Configuration Register is not an internal ADC register but an external register.

Communications Register of M76/AD7714 (0x08)

| | | | | |
|-------|----------------------|------|-------------------|------|
| 15..8 | 7 | 6..4 | 3 | 2..0 |
| - | 0/ \overline{DRDY} | RS | R/ \overline{W} | CH |

$0/\overline{DRDY}$ For a write operation, a 0 must be written to this bit so that the write operation to the Communications Register actually takes place. If a 1 is written to this bit, the part will not clock on to subsequent bits in the register. It will stay at this bit location until a 0 is written to this bit. Once a 0 is written to this bit, the next 7 bits will be loaded to the Communications Register. For a read operation, this bit provides the status of the \overline{DRDY} flag from the component. The status of this bit is the same as the $/DRDY$ output pin.

Note: The $DRDY$ bit in the Status Register is non-inverted (active-high). See [Chapter Status Register \(0x0C\) \(read\) on page 30](#).

RS Register Selection of ADC

Table 7. Register Selection of ADC

| RS2..0 | Register | Size |
|---------------|--|-------------|
| 0 0 0 | Communications Register | 8 bits |
| 0 0 1 | Mode Register | 8 bits |
| 0 1 0 | Filter High Register | 8 bits |
| 0 1 1 | Filter Low Register | 8 bits |
| 1 0 0 | Test Register | 8 bits |
| 1 0 1 | Data Register (read only)/Configuration Register (write only) (external) | 24 bits |
| 1 1 0 | Zero-Scale Calibration Register | 24 bits |
| 1 1 1 | Full-Scale Calibration Register | 24 bits |

R/\overline{W} Read/write select. This bit selects whether the next operation is a read or write operation to the selected register.
 0 = Write access
 1 = Read access

CH Channel select
 0 1 0 = AIN3, resistance, measuring current I_M
 0 1 1 = AIN4, resistance, measuring voltage U_x
 1 0 0 = AIN1/AIN2, DC voltage/current
 1 1 0 = AIN5, AC voltage/current

Also see [Table 8, Applicable Channels of the ADC, on page 22](#).

The data written to this register determines whether the next operation to the component is a read or a write operation and also determines to which register this read or write operation occurs. Therefore, write access to any of the other registers on the component starts with a write operation to the Communications Register followed by a write to the selected register. A read operation from any other register on the component (including the output data register) starts with a write operation to the Communications Register followed by a read operation from the selected register.

Mode Register (0x08, RS = 001)

| | | | |
|------|------|----|-------|
| 7..5 | 4..2 | 1 | 0 |
| MD | G | BO | FSYNC |

The Mode Register determines the calibration mode and gain setting.

- MD** Operating mode
 0 0 0 = Normal mode (default)
 0 0 1 .. 1 1 1 = Calibration modes
- G** Gain setting
 0 0 0 = Gain 1 (for DC and resistance measurements, and AC measurements with crest factors ≤ 4)
 0 0 1 = Gain 2 (for AC measurements with crest factors ≤ 8)
 0 1 0 = Gain 4 (for resistance measurements in the lowest range, for measuring voltage U_x)
 Also see [Table 8, Applicable Channels of the ADC, on page 22](#).
- BO** Burn-out current (always 0)
- FSYNC** Filter synchronization (always 0)

Filter High Register (0x08, RS = 010)

| | | | | |
|-------------|----|-----|------|-----------|
| 7 | 6 | 5 | 4 | 3..0 |
| \bar{B}/U | WL | BST | ZERO | FS11..FS8 |

- \bar{B}/U** Bipolar/unipolar operation
 0 = Bipolar (standard for DC measurements)
 1 = Unipolar (standard for AC and resistance measurements)
 Also see [Table 8, Applicable Channels of the ADC, on page 22](#).
- WL** Word length (always 1)
 1 = 24-bit word length
- BST** Current boost (always 0)
- ZERO** To ensure correct operation of the chip, a 0 must be written to this bit.
- FS11..FS8** Filter selection, upper 4 bits of the filter selection word (see below).

Filter Low Register (0x08, RS = 011)

| |
|----------|
| 7..0 |
| FS7..FS0 |

This register contains the lower 8 bits of the filter selection word (*FS7..FS0*).

The on-chip digital filter provides a Sinc³ (or (Sin π /x)³) filter response. The 12 bits of data programmed into these bits determine the filter cut-off frequency, the position of the first notch of the filter and the data rate for the part. In association with the gain selection, it also determines the output noise (and hence the effective resolution) of the device.

The first notch of the filter occurs at a frequency determined by the relationship:

$$frequency = \frac{\left(\frac{f_{clk_{in}}}{128}\right)}{code}$$

code is the decimal equivalent of the code in bits *FS0..FS11* and is in the range 19..4,000. *f_{clk_{in}}* is 2.4576MHz.

Test Register (0x08, RS = 100)

The Test Register is provided for testing the device. The user is advised not to change the status of any of the bits in this register.

Data Register (0x08, RS = 101) (read-only)

The Data Register contains the most up-to-date conversion result from the AD7714. The register is programmed to be 24 bits wide, determined by the status of the *WL* bit of the Filter High Register. If the Communications Register data sets up the component for a write operation to this register, a write operation must actually take place in order to return the component to where it is expecting a write operation to the Communications Register (the default state of the interface).

Zero-Scale/Full-Scale Calibration Registers (0x08, RS = 110/111)

The Zero-Scale and Full-Scale Calibration Registers allow access to the zero/full-scale calibration coefficients for the selected input channel.

Table 11, [Factory Setting of Calibration Values in the User EEPROM](#), on page 34 lists all calibration values. Each time the range is changed the corresponding values must be loaded before a measurement can be started.

For a more detailed description of the individual registers please refer to the data sheet of the ADC device (see [Chapter 5.1 Literature and WWW Resources](#) on page 37).

4.2 Configuring the M-Module

You can make basic configuration of the M-Module conveniently through the Configuration Register. The 24-bit Configuration word presets the M-Module for the type of measurement as well as for specific measuring ranges.

In addition, you need to configure the A/D converter directly, e. g. to select a channel and to set a gain value.

For a typical configuration sequence, please refer to MEN's M76 MDIS4 driver package (*M76_Init*).

The following table gives an overview of the different channels with the corresponding ADC inputs and input voltages.

Table 8. Applicable Channels of the ADC

| Measurement Mode | ADC Inputs | ADC Input Voltage | Type | CH | Gain | Operation |
|-------------------------------------|------------|-------------------|---------------------|-----|-------------------|-----------|
| DC voltage/current | AIN1 | 2.5V \pm 1.25V | Fully differential | 100 | 1 | Bipolar |
| | AIN2 | 2.5V \pm 1.25V | | | | |
| AC voltage/current | AIN5 | 0..2.5V | Fully differential | 110 | 1, 2 ¹ | Unipolar |
| | AIN6 | COM (0V) | | | | |
| Resistance, measuring current I_M | AIN3 | 0..2.5V | Pseudo differential | 010 | 1 | Unipolar |
| Resistance, measuring voltage U_x | AIN4 | 0..2.5V | Pseudo differential | 011 | 1, 4 ² | |

¹ Use gain = 1 for crest factor \leq 4; use gain = 2 for crest factors up to 8 and half the RMS range.

² Use gain = 4 with the lowest measuring range.



Note: The ADC's internal input buffer is disabled on the M76 (= unbuffered mode). The *BUFFER* pin is connected to *GND*.

Configuration Register (0x04/0x06) (write)

| | | |
|-----------------------|----------------------|------|
| 31..16 | 15..8 | 7..0 |
| Configuration D23..D8 | Configuration D7..D0 | - |

The following table gives you all register values for the different measuring modes.

Table 9. Setting a Measuring Mode through the Configuration Register

| Measuring Mode | Hex Value (Configuration) |
|---|---------------------------|
| DC voltage, 125mV | 0x 06 FA EE 00 |
| DC voltage, 1.25V | 0x 06 FA ED 00 |
| DC voltage, 12.5V | 0x 02 FA EE 00 |
| DC voltage, 125V | 0x 02 FA ED 00 |
| DC voltage, 500V (identical with 125V DC voltage, but use HIGH_VOLTAGE input) | 0x 02 FA ED 00 |
| AC voltage, 250mV _{RMS} | 0x 04 FB FD 00 |
| AC voltage, 2.5V _{RMS} | 0x 04 FB EE 00 |
| AC voltage, 25V _{RMS} | 0x 04 FB DE 00 |
| AC voltage, 250V _{RMS} (use HIGH_VOLTAGE input) | 0x 04 FB BE 00 |
| DC current, 12.5mA | 0x 28 7D FD 00 |
| DC current, 125mA | 0x 28 BD FD 00 |
| DC current, 1.25A | 0x 30 DD FD 00 |
| DC current, 2.5A | 0x 30 ED FD 00 |
| AC current, 25mA _{RMS} | 0x 08 77 FD 00 |
| AC current, 250mA _{RMS} | 0x 08 B7 FD 00 |
| AC current, 2.5A _{RMS} | 0x 10 D7 FD 00 |
| Resistance, 2-wire, 0Ω..250Ω, R _S = 1kΩ | 0x 4B F9 BD 00 |
| Resistance, 2-wire, 250Ω..2.5kΩ, R _S = 1kΩ | 0x 4B F9 BD 00 |
| Resistance, 2-wire, 2.5kΩ..25kΩ, R _S = 10kΩ | 0x 4B F9 DD 00 |
| Resistance, 2-wire, 25kΩ..250kΩ, R _S = 0.1MΩ | 0x 4B F9 ED 00 |
| Resistance, 2-wire, 250kΩ..2.5MΩ, R _S = 1MΩ | 0x 4B F9 F5 00 |
| Resistance, 4-wire, 0Ω..250Ω, R _S = 1kΩ | 0x 43 F9 BD 00 |
| Resistance, 4-wire, 250Ω..2.5kΩ, R _S = 1kΩ | 0x 43 F9 BD 00 |
| Resistance, 4-wire, 2.5kΩ..25kΩ, R _S = 10kΩ | 0x 43 F9 DD 00 |
| Resistance, 4-wire, 25kΩ..250kΩ, R _S = 0.1MΩ | 0x 43 F9 ED 00 |
| Resistance, 4-wire, 250kΩ..2.5MΩ, R _S = 1MΩ | 0x 43 F9 F5 00 |

4.3 Making Measurements

4.3.1 DC Voltage Measurement

For DC voltage measurement the M76 uses input channels AIN1 and AIN2 of the AD7714 (see [Chapter Communications Register of M76/AD7714 \(0x08\) on page 19](#)).

There are five measuring ranges for DC voltage measurement. Connection is via **U** and **COM**, and via **HIGH_VOLTAGE** and **COM** for the 500V range. You must select the input channel through the [Communications Register](#).

Measuring ranges:

- -125mV..+125mV (connector pins U and COM)
- -1.25V..+1.25V (connector pins U and COM)
- -12.5V..+12.5V (connector pins U and COM)
- -125V..+125V (connector pins U and COM)
- -500V..+500V (connector pins HIGH_VOLTAGE and COM)

You can make all necessary range settings in the Configuration Register, see [Table 9, Setting a Measuring Mode through the Configuration Register, on page 23](#).

According to the safety requirements of EN60950 and EN61010 the maximum input voltage is limited to 500V. The degree of soiling is 1.



Note: Observe the safety warnings given in [Chapter Product Safety on page 7](#) and [Chapter 2 Connecting the M-Module on page 12](#).

4.3.2 AC Voltage Measurement

For AC voltage measurement the M76 uses input channel AIN5 of the AD7714 (see [Communications Register of M76/AD7714 \(0x08\)](#)). The AD637A calculates the root mean square value.

There are four standard measuring ranges for AC voltage measurement. Connection is via **U** and **COM**, and via **HIGH_VOLTAGE** and **COM** for the 500V range. You must select the input channel through the [Communications Register](#).

Measuring ranges (crest factor ≤ 4 ; gain = 1):

- $250\text{mV}_{\text{RMS}}$ (connector pins U and COM)
- 2.5V_{RMS} (connector pins U and COM)
- 25V_{RMS} (connector pins U and COM)
- 250V_{RMS} (connector pins HIGH_VOLTAGE and COM)

Alternatively, you can operate the M-Module with gain = 2, resulting in a crest factor of ≤ 8 and the following applicable measuring ranges:

- $125\text{mV}_{\text{RMS}}$ (range settings correspond to $250\text{mV}_{\text{RMS}}$ standard range)
- $1.25\text{V}_{\text{RMS}}$ (range settings correspond to 2.5V_{RMS} standard range)
- $12.5\text{V}_{\text{RMS}}$ (range settings correspond to 25V_{RMS} standard range)
- 125V_{RMS} (range settings correspond to 250V_{RMS} standard range)

Note: AC measurement errors increase approx. at crest factor $\text{CF} = 5$; i. e. 12.5V range error $< 0.5\%$.

See [Mode Register \(0x08, RS = 001\)](#) on how to set the gain value.

You can make all necessary range settings in the Configuration Register, see [Table 9, Setting a Measuring Mode through the Configuration Register](#), on page 23.

According to the safety requirements of EN60950 and EN61010 the maximum input voltage is limited to 500V. The degree of soiling is 1.



Note: With measurements in the lower measuring ranges, there may be measuring errors. This is caused by non-linearity of the RMS-to-DC converter.



Note: Observe the safety warnings given in [Chapter Product Safety on page 7](#) and [Chapter 2 Connecting the M-Module on page 12](#).

4.3.3 DC Current Measurement

For DC current measurement the M76 uses input channels AIN1 and AIN2 of the AD7714 (see [Communications Register of M76/AD7714 \(0x08\)](#)).

There are four measuring ranges for DC current measurement. Connection is via inputs **I** and **COM**. You must select the input channel through the [Communications Register](#).

Measuring ranges:

- -12.5mA..+12.5mA (1Ω shunt)
- -125mA..+125mA (1Ω shunt)
- -1.25A..+1.25A (0.1Ω shunt)
- -2.5A..+2.5A (0.1Ω shunt)

You can make all necessary settings for each range in the Configuration Register, see [Table 9, Setting a Measuring Mode through the Configuration Register](#), on page 23.



Note: Observe the safety warnings given in [Chapter Product Safety on page 7](#) and [Chapter 2 Connecting the M-Module on page 12](#).

4.3.4 AC Current Measurement

For AC current measurement the M76 uses input channel AIN5 of the AD7714 (see [Communications Register of M76/AD7714 \(0x08\)](#)).

There are three measuring ranges for AC current measurement. Connection is via inputs **I** and **COM**. You must select the input channel through the [Communications Register](#).

Measuring ranges (crest factor ≤ 4 ; gain = 1):

- 25mA_{RMS} (1Ω shunt)
- 250mA_{RMS} (1Ω shunt)
- 2.5A_{RMS} (0.1Ω shunt)

Alternatively, you can operate the M-Module with gain = 2, resulting in a crest factor of ≤ 8 and the following applicable measuring ranges:

- 12.5mA_{RMS} (range settings correspond to 25mA_{RMS} standard range)
- 125mA_{RMS} (range settings correspond to 250mA_{RMS} standard range)
- 1.25A_{RMS} (range settings correspond to 2.5A_{RMS} standard range)

Note: AC measurement errors increase approx. at Crest factor CF = 5; i. e. range error < 1%.

See [Mode Register \(0x08, RS = 001\)](#) on how to set the gain value.

You can make all necessary settings for each range in the Configuration Register, see [Table 9, Setting a Measuring Mode through the Configuration Register](#), on page 23.



Note: Observe the safety warnings given in [Chapter Product Safety on page 7](#) and [Chapter 2 Connecting the M-Module on page 12](#).

4.3.5 Resistance Measurement

For resistance measurement the M76 uses input channels AIN3 and AIN4 of the AD7714 (see [Communications Register of M76/AD7714 \(0x08\)](#)).

The M-Module supports two-wire and four-wire measurements.

Measuring ranges:

- 250Ω
- 2.5kΩ
- 25kΩ
- 250kΩ
- 2.5MΩ

The maximum measuring voltage is 2.5V.

You can make all necessary settings for each range in the Configuration Register, see [Table 9, Setting a Measuring Mode through the Configuration Register, on page 23](#).

4.3.5.1 Measuring Principle

The M76 has no adjustable current source. Instead, the measuring current I_M is limited to a series resistance that can be set to six different values. The following figure shows the general circuitry for resistance measurements:

Figure 2. Measuring Principle of Resistance Measurements

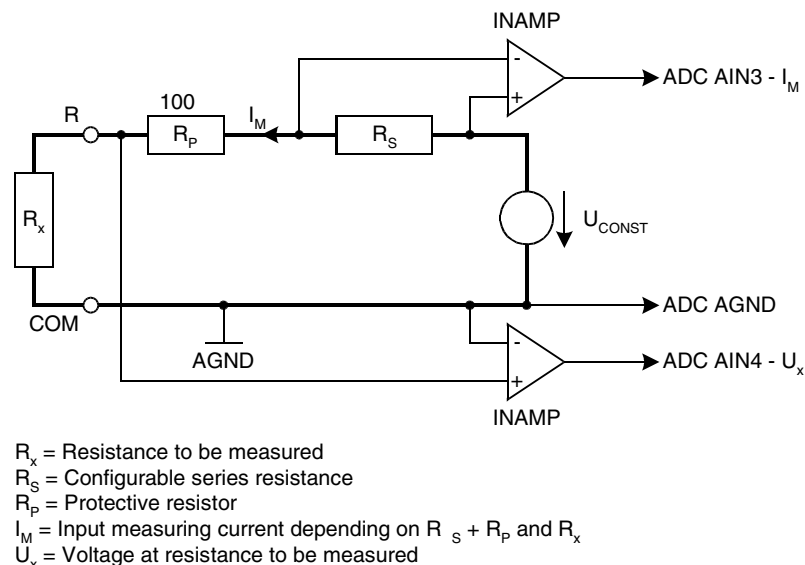

The series resistance is selected through the [Configuration Register](#) as is appropriate for the measuring range. For the resistance value, there are four decimal steps from 1kΩ to 1MΩ. (See [Table 9, Setting a Measuring Mode through the Configuration Register, on page 23](#).)

The size of measuring current I_M is available through the A/D converter's input channel AIN3 (see [Communications Register of M76/AD7714 \(0x08\)](#)). Knowing this current, you can fetch voltage U_x at the resistance to be measured. The unknown resistance is then

$$R_x = \frac{U_x}{I_M}$$

In order to obtain the highest possible accuracy, the appropriate onboard series resistance should be selected for the estimated value of the device under test (DUT).

Table 10. Selecting the Series Resistance for Resistance Measurement

| R_S | Measuring Range |
|---------------|-----------------|
| 1k Ω | 250 Ω |
| 1k Ω | 2.5k Ω |
| 10k Ω | 25k Ω |
| 0.1M Ω | 250k Ω |
| 1M Ω | 2.5M Ω |

4.3.5.2 2-Wire Measurement

Connection with two-wire measurement is via **R** and **COM**. You must select the input channel through the [Communications Register](#).

Figure 3. 2-Wire Resistance Measurement

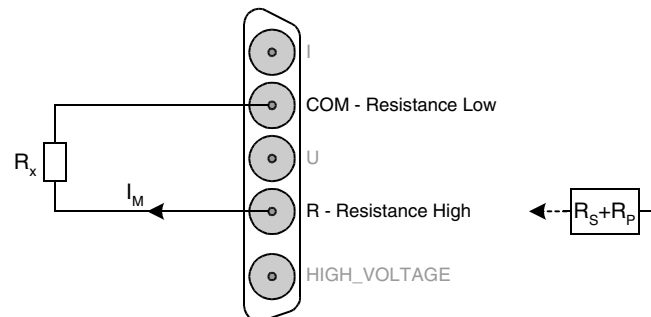

R_x = Resistance to be measured
 R_S = Configurable series resistance
 R_P = Protective resistor
 I_M = Input measuring current depending on $R_S + R_P$ and R_x



Note: Any devices connected to inputs I and/or U may remain connected.
 Don't connect any voltage or current sources to input R!

4.3.5.3 4-Wire Measurement

Connection with four-wire measurement via **R** and **COM** as a current path and **I** and **U** as a voltage path. You must select the input channel through the [Communications Register](#).

Figure 4. 4-Wire Resistance Measurement

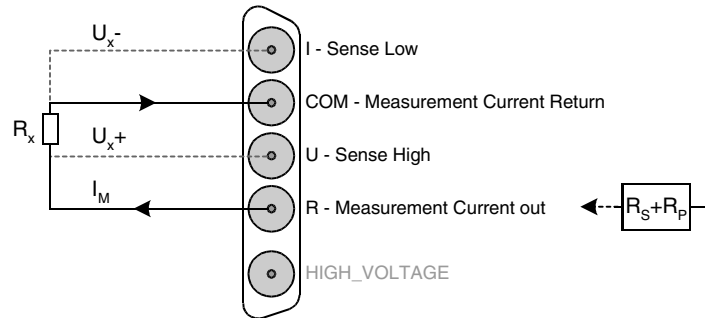

R_x = Resistance to be measured
 R_s = Configurable series resistance
 R_p = Protective resistor
 I_M = Input measuring current depending on R_s+R_p and R_x
 $U_{x\pm}$ = Voltage sense



Note: Remove any voltage or current sources connected to inputs I and/or U!
 Don't connect any voltage or current sources to input R!

Application Example: Strain Gage Measurements

You can perform simple strain gage measurements with 4-wire connection, e.g. with a series resistance of 100Ω:

Figure 5. Application Example: Strain Gage Measurements with 4-Wire Connection

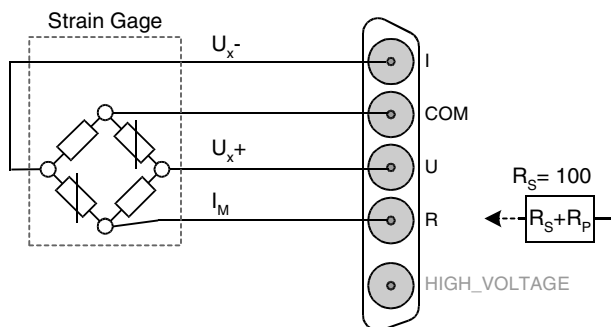

R_s = Series resistance
 R_p = Protective resistor
 I_M = Input measuring current depending on R_s+R_p and R_x
 $U_{x\pm}$ = Voltage sense

4.4 Reading Measuring Data

You can read measuring data through the Data Register of the M76. This register contains the 24-bit data from the A/D converter's Data Register. The [Access Register](#) allows you to start a data read transfer from the A/D converter. To check whether the serial data transfer or the data is ready, you can poll the [Status Register](#).

For a typical reading sequence, please refer to MEN's M76 MDIS4 driver package (*M76_Read*).

Access Register (0x0A) (write)

| | | | | |
|-------|-------|-------|------|-----|
| 15..4 | 3 | 2 | 1 | 0 |
| - | IRQEN | TR24R | TR24 | TR8 |

| | |
|--------------|---|
| <i>IRQEN</i> | IRQ enable 0 = Disable interrupt 1 = Enable interrupt, i.e. trigger an interrupt after a read transfer |
| <i>TR24R</i> | 24-bit read transfer waiting for data ready signal from the ADC 1 = Start 24-bit read transfer after <i>DRDY</i> |
| <i>TR24</i> | 24-bit read transfer 1 = Start 24-bit read transfer immediately |
| <i>TR8</i> | 8-bit read transfer 1 = Start 8-bit read transfer immediately |

Status Register (0x0C) (read)

| | | | | |
|-------|------|-------|------|------|
| 15..4 | 3 | 2 | 1 | 0 |
| - | IRQP | TRDYR | TRDY | DRDY |

| | |
|--------------|---|
| <i>IRQP</i> | IRQ pending 1 = Interrupt is pending. This bit can be reset by writing 0 to bit <i>IRQEN</i> . |
| <i>TRDYR</i> | Transfer ready on request 1 = ADC has transferred new data after <i>/DRDY</i> went to "low". (Status signal for <i>TR24R</i> .) |
| <i>TRDY</i> | Transfer ready 1 = Serial transfer of a value has been completed. This bit can be polled before reading data from the Data Register. |
| <i>DRDY</i> | Data ready 1 = New measuring data is available in the ADC. The bit is 0 during a calibration cycle, but it is 1 at the end of the calibration cycle. |



Note: The */DRDY* output pin of the ADC is active-low, but the *DRDY* bit in the Status Register of the M76 is active-high!

Data Register (0x00/0x02) (read/write)

| | | | |
|-----|-------|-----|------|
| | 31..9 | | 7..0 |
| MSB | Data | LSB | - |

The data format is 24 bits left-aligned, the lowest negative voltage value having code 0x000000, the highest positive voltage value having code 0xFFFFFF.

To read out the desired measuring value, you need to set the ADC to the correct channel through the *CH* bits in the Communications Register. See [Table 8, Applicable Channels of the ADC, on page 22](#).

4.5 M-Module Control Options

The Control Register offers the option of resetting the ADC and Configuration Register and of changing between the M-Module ID and User EEPROM:

Control Register (0x0E) (write)

| | | | |
|-------|-------|-----|---|
| 15..3 | 2 | 1 | 0 |
| - | EESEL | RST | - |

EESEL EEPROM select
 0 = Select M-Module Identification EEPROM
 1 = Select User EEPROM

RST ADC/Configuration Register reset
 0 = Reset ADC/Configuration Register
 1 = No ADC/Configuration Register reset
 This bit must be 1 during operation.



At power-up the ADC and Configuration Register are in reset state (*RST* = 0). For M-Module operation the *RST* bit must be set to 1.

4.6 M-Module Identification and User EEPROM

The M76 M-Module is supplied with an identification EEPROM in accordance with the M-Module specification and an additional User EEPROM. Both EEPROMs are accessible via the M-Module Identification/User EEPROM Register at offset address 0xFE. You can change between the two EEPROMs through bit *EESEL* in the Control Register, see [Chapter 4.5 M-Module Control Options on page 32](#).

M-Module Identification/User EEPROM Register (0xFE) (read/write)

| | | | | |
|-------|------|----|-----|------|
| 15..8 | 7..3 | 2 | 1 | 0 |
| - | - | CS | CLK | DATA |

CS 1 = Chip-select for EEPROM (read)

CLK EEPROM clock (read)

DATA EEPROM data (read/write)

4.6.1 Data Structure in the User EEPROM

The User EEPROM contains 256 words of 16 bits each. To ensure accurate measurements, the data stored in the EEPROM must be written to the Calibration Register when changing the measuring range.

If you want to develop your own software and program the User EEPROM on your own, you should take the following into consideration:

Each configuration value is 24 bits long, so you need two 16-bit words in the EEPROM for each 24-bit value.

You need 64 bits for each possible measuring range:

- 32 bits for zero calibration, and
- 32 bits for full-scale calibration.

For the individual measuring ranges this means:

- DC voltage 5 x 64 bits
- AC voltage 4 x 64 bits
- DC current 4 x 64 bits
- AC current 3 x 64 bits
- Resistance 2-wire 10 x 64 bits
- Resistance 4-wire 10 x 64 bits

which makes a total of 36 64-bit calibration values, i.e. 2304 bits.

The factory setting of calibration values in the User EEPROM is as follows:

Table 11. Factory Setting of Calibration Values in the User EEPROM

| Address | Calibration | Contents | |
|------------|-------------|----------------------|---------------------|
| 0x00, 0x01 | Zero-scale | 125mV | DC voltage bipolar |
| 0x02, 0x03 | Full-scale | | |
| 0x04, 0x05 | Zero-scale | 1.25V | |
| 0x06, 0x07 | Full-scale | | |
| 0x08, 0x09 | Zero-scale | 12.5V | |
| 0x0A, 0x0B | Full-scale | | |
| 0x0C, 0x0D | Zero-scale | 125V | |
| 0x0E, 0x0F | Full-scale | | |
| 0x10, 0x11 | Zero-scale | 500V | |
| 0x12, 0x13 | Full-scale | | |
| 0x14, 0x15 | Zero-scale | 250mV _{RMS} | AC voltage unipolar |
| 0x16, 0x17 | Full-scale | | |
| 0x18, 0x19 | Zero-scale | 2.5V _{RMS} | |
| 0x1A, 0x1B | Full-scale | | |
| 0x1C, 0x1D | Zero-scale | 25V _{RMS} | |
| 0x1E, 0x1F | Full-scale | | |
| 0x20, 0x21 | Zero-scale | 250V _{RMS} | |
| 0x22, 0x23 | Full-scale | | |
| 0x24, 0x25 | Zero-scale | 12.5mA | DC current bipolar |
| 0x26, 0x27 | Full-scale | | |
| 0x28, 0x29 | Zero-scale | 125mA | |
| 0x2A, 0x2B | Full-scale | | |
| 0x2C, 0x2D | Zero-scale | 1.25A | |
| 0x2E, 0x2F | Full-scale | | |
| 0x30, 0x31 | Zero-scale | 2.5A | |
| 0x32, 0x33 | Full-scale | | |
| 0x34, 0x35 | Zero-scale | 25mA _{RMS} | AC current unipolar |
| 0x36, 0x37 | Full-scale | | |
| 0x38, 0x39 | Zero-scale | 250mA _{RMS} | |
| 0x3A, 0x3B | Full-scale | | |
| 0x3C, 0x3D | Zero-scale | 2.5A _{RMS} | |
| 0x3E, 0x3F | Full-scale | | |

| Address | Calibration | Contents | | |
|------------|-------------|---|-------|-----------------------------------|
| 0x40, 0x41 | Zero-scale | $R_S = 1k\Omega$ (0 Ω ..250 Ω) | U_x | Resistance measurement, 2-wire |
| 0x42, 0x43 | Full-scale | | I_M | |
| 0x44, 0x45 | Zero-scale | | I_M | |
| 0x46, 0x47 | Full-scale | | U_x | |
| 0x48, 0x49 | Zero-scale | $R_S = 1k\Omega$ (250 Ω ..2.5k Ω) | U_x | |
| 0x4A, 0x4B | Full-scale | | I_M | |
| 0x4C, 0x4D | Zero-scale | | I_M | |
| 0x4E, 0x4F | Full-scale | | U_x | |
| 0x50, 0x51 | Zero-scale | $R_S = 10k\Omega$ (2.5k Ω ..25k Ω) | U_x | |
| 0x52, 0x53 | Full-scale | | I_M | |
| 0x54, 0x55 | Zero-scale | | I_M | |
| 0x56, 0x57 | Full-scale | | U_x | |
| 0x58, 0x59 | Zero-scale | $R_S = 0.1M\Omega$ (25k Ω ..250k Ω) | U_x | |
| 0x5A, 0x5B | Full-scale | | I_M | |
| 0x5C, 0x5D | Zero-scale | | I_M | |
| 0x5E, 0x5F | Full-scale | | U_x | |
| 0x60, 0x61 | Zero-scale | $R_S = 1M\Omega$ (250k Ω ..2.5M Ω) | U_x | |
| 0x62, 0x63 | Full-scale | | I_M | |
| 0x64, 0x65 | Zero-scale | | I_M | |
| 0x66, 0x67 | Full-scale | | U_x | |

| Address | Calibration | Contents | | |
|------------|-------------|---|-------|-----------------------------------|
| 0x68, 0x69 | Zero-scale | $R_S = 1k\Omega$ (0 Ω ..250 Ω) | U_x | Resistance measurement, 4-wire |
| 0x6A, 0x6B | Full-scale | | I_M | |
| 0x6C, 0x6D | Zero-scale | | I_M | |
| 0x6E, 0x6F | Full-scale | | U_x | |
| 0x70, 0x71 | Zero-scale | $R_S = 1k\Omega$ (250 Ω ..2.5k Ω) | U_x | |
| 0x72, 0x73 | Full-scale | | I_M | |
| 0x74, 0x75 | Zero-scale | | I_M | |
| 0x76, 0x77 | Full-scale | | U_x | |
| 0x78, 0x79 | Zero-scale | $R_S = 10k\Omega$ (2.5k Ω ..25k Ω) | U_x | |
| 0x7A, 0x7B | Full-scale | | I_M | |
| 0x7C, 0x7D | Zero-scale | | I_M | |
| 0x7E, 0x7F | Full-scale | | U_x | |
| 0x80, 0x81 | Zero-scale | $R_S = 0.1M\Omega$ (25k Ω ..250k Ω) | U_x | |
| 0x82, 0x83 | Full-scale | | I_M | |
| 0x84, 0x85 | Zero-scale | | I_M | |
| 0x86, 0x87 | Full-scale | | U_x | |
| 0x88, 0x89 | Zero-scale | $R_S = 1M\Omega$ (250k Ω ..2.5M Ω) | U_x | |
| 0x8A, 0x8B | Full-scale | | I_M | |
| 0x8C, 0x8D | Zero-scale | | I_M | |
| 0x8E, 0x8F | Full-scale | | U_x | |

5 Appendix

5.1 Literature and WWW Resources

- M-Module Standard:
ANSI/VITA 12-1996, M-Module Specification;
VMEbus International Trade Association
7825 E. Gelding Dr., Ste. 104,
Scottsdale, AZ 85260
www.vita.com
- A/D Converter (AD7714)
Design-in Reference Manual, 1994,
ANALOG DEVICES Inc.
(we strongly recommend this manual!)
www.analog.com
- RMS-to-DC converter (AD637A)
High Precision, Wide-Band RMS-to-DC Converter AD637A,
1999, ANALOG DEVICES Inc.
www.analog.com

5.2 Board Revisions

Table 12. Table of Hardware Revisions

| Revision | Comment | Restrictions |
|----------|--------------------------|--|
| 00.xx | Prototype | Max. input voltage: 250V high-voltage input 63V normal input |
| 01.xx | First revision released | None known |
| 02.xx | Second revision released | None known |

5.3 Component Plans

Figure 6. Component Plan of M76 Hardware Revision 02 - Top side

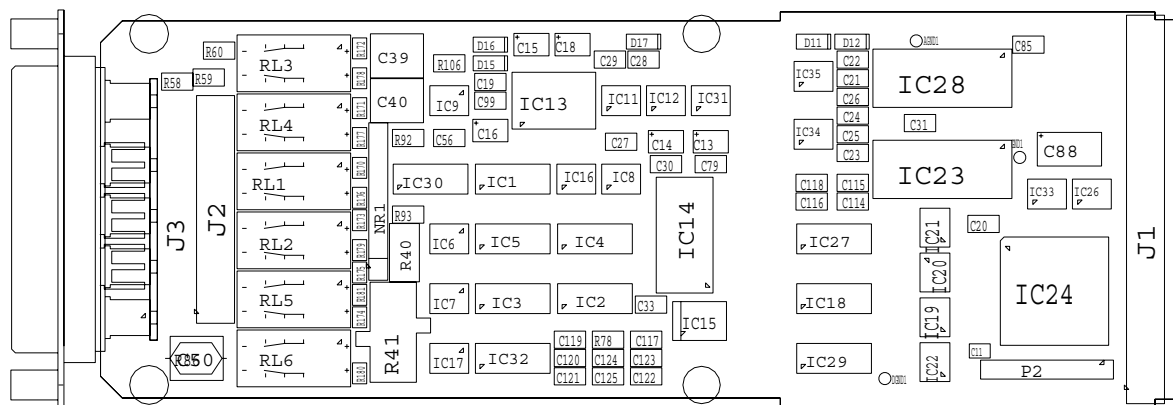
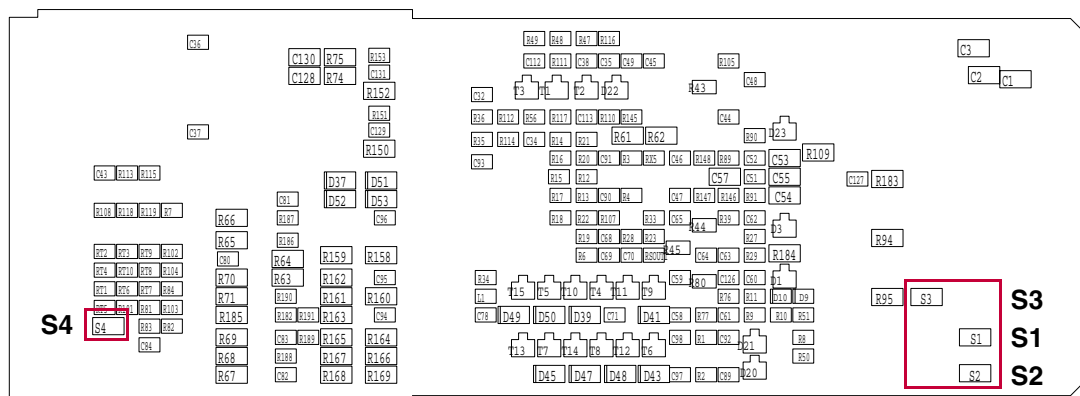

Figure 7. Component Plan of M76 Hardware Revision 02 - Bottom side



You can request the circuit diagrams for the current revision of the product described in this manual by completely filling out and signing the following non-disclosure agreement.

Please send the agreement to MEN by mail. We will send you the circuit diagrams along with a copy of the completely signed agreement by return mail.

MEN reserves the right to refuse sending of confidential information for any reason that MEN may consider substantial.



Non-Disclosure Agreement

for Circuit Diagrams provided by MEN Mikro Elektronik GmbH

between

MEN Mikro Elektronik GmbH
Neuwieder Straße 7
D-90411 Nürnberg

("MEN")

and

("Recipient")

We confirm the following Agreement:

MEN

Date: _____

Name: _____

Function: _____

Recipient

Date: _____

Name: _____

Function: _____

Signature:

Signature:

The following Agreement is valid as of the date of MEN's signature.

MEN Mikro Elektronik GmbH

Neuwieder Straße 7
90411 Nürnberg
Deutschland

Tel. +49-911-99 33 5-0
Fax +49-911-99 33 5-99

E-Mail info@men.de
www.men.de

Non-Disclosure Agreement for Circuit Diagrams page 1 of 2

1 Subject

The subject of this Agreement is to protect all information contained in the circuit diagrams of the following product:

Article Number: _____ [filled out by recipient]

MEN provides the recipient with the circuit diagrams requested through this Agreement only for information.

2 Responsibilities of MEN

Information in the circuit diagrams has been carefully checked and is believed to be accurate as of the date of release; however, no responsibility is assumed for inaccuracies. MEN will not be liable for any consequential or incidental damages arising from reliance on the accuracy of the circuit diagrams. The information contained therein is subject to change without notice.

3 Responsibilities of Recipient

The recipient, obtaining confidential information from MEN because of this Agreement, is obliged to protect this information.

The recipient will not pass on the circuit diagrams or parts thereof to third parties, neither to individuals nor to companies or other organizations, without the written permission by MEN. The circuit diagrams may only be passed to employees who need to know their content. The recipient protects the confidential information obtained through the circuit diagrams in the same way as he protects his own confidential information of the same kind.

4 Violation of Agreement

The recipient is liable for any damage arising from violation of one or several sections of this Agreement. MEN has a right to claim damages amounting to the damage caused, at least to €100,000.

5 Other Agreements

MEN reserves the right to pass on its circuit diagrams to other business relations to the extent permitted by the Agreement.

Neither MEN nor the recipient acquire licenses for the right of intellectual possession of the other party because of this Agreement.

This Agreement does not result in any obligation of the parties to purchase services or products from the other party.

6 Validity of Agreement

The period after which MEN agrees not to assert claims against the recipient with respect to the confidential information disclosed under this Agreement shall be _____ months [filled out by MEN]. (Not less than twenty-four (24) nor more than sixty (60) months.)

7 General

If any provision of this Agreement is held to be invalid, such decision shall not affect the validity of the remaining provisions and such provision shall be reformed to and only to the extent necessary to make it effective and legal.

This Agreement is only effective if signed by both parties.

Amendments to this Agreement can be adopted only in writing. There are no supplementary oral agreements.

This Agreement shall be governed by German Law.

The court of jurisdiction shall be Nuremberg.



MEN Mikro Elektronik GmbH

Neuwieder Straße 7
90411 Nürnberg
Deutschland

Tel. +49-911-99 33 5-0
Fax +49-911-99 33 5-99

E-Mail info@men.de
www.men.de